

# *Bike Rack Series*

model no:

*BRK534I, BRK535I, BRK536I,  
BRK538I, BRK534S, BRK535S,  
BRK536S, BRK538S*

SERPENTINE BIKE RACK  
SURFACE MOUNT, INGROUND

---

## *customer service:*

ASSEMBLERS: If you find any parts missing or damaged, or if you're having difficulty assembling your furniture/equipment, call us at:

\* Before calling, have your product model number available.

1-800-253-8619 (Inside U.S.A.)  
260-352-2102 (Outside U.S.A.)  
Monday thru Friday,  
8:00 AM - 4:30 PM Eastern Time  
(EXCEPT HOLIDAYS)

---

## *maintenance:*

Regular inspection and maintenance of all parts, and fasteners is necessary. Tighten all bolts and nuts. Inspect Tops, Seats, Legs, Braces and Fasteners periodically for wear or vandalism. Replace broken or worn parts immediately or take equipment out of service until repairs are made. Use genuine replacement parts.

KEEP THIS ASSEMBLY/SPECIFICATION SHEET FOR FUTURE REFERENCE.

---

## *specifications:*

NOTE: We reserve the right to change specifications without notice.

Framework assemblies are finished with powder coating; electrostatically applied and oven cured according to powder manufacturer's specifications. Fasteners are stainless steel to resist corrosion.

### FRAME:

BRK538I & BRK538S

The Bike Rack tube consists of 13 gage x 2 3/8" diameter mechanical steel tubing. The base plate for the surface mount unit is 7 gage thick x 6" steel plate.

### ALL OTHER MODELS

The Bike Rack tube consists of 1 7/8" diameter mechanical steel tubing. The base plate for the surface mount unit is 1/4" thick x 4" steel plate.

### GENERAL DIMENSIONS:

Ground space requirements for the inground units.

BRK534I- 1 7/8" deep x 63 3/4" wide x 35" tall.  
BRK535I- 1 7/8" deep x 88 1/2" wide x 35" tall.  
BRK536I- 1 7/8" deep x 113 1/4" wide x 35" tall.  
BRK538I- 2 3/8" deep x 50 3/8" wide x 35" tall.

Ground space requirements for the surface mount units.

BRK534S- 4" deep x 65 7/8" wide x 35" tall.  
BRK535S- 4" deep x 90 5/8" wide x 35" tall.  
BRK536S- 4" deep x 115 3/8" wide x 35" tall.  
BRK538S- 6" deep x 54" wide x 35" tall.

NOTE: SERPENTINE BIKE RACK SECURES 5 TO 11 BIKES DEPENDING ON MODEL.

## Finished to Look Like Wood, but Act Like Metal

Our faux-wood finishes so closely resemble the real thing that it's hard to believe it's metal and not wood. The timeless beauty and tradition of wood without any of the headaches, such as cracking, warping or rotting. For superior strength and rigidity, we add reinforcements to the aluminum extrusions for all of our faux-wood-finished products.



## AAMA 2604-05 Certification

Our seven-step powder-coat system exceeds AAMA 2604-05 (American Architectural Manufacturers Association) test specifications—one of the highest in the industry. Our coating stood up to some of the toughest test specifications, including adhesion, abrasion resistance, chemical resistance, corrosion resistance and fade resistance, to ensure that our products will last longer than anyone else's.

### AAMA 2604-05 test Procedures and Performance Requirements

Test Requirements	Compliance
<b>Salt-Spray Resistance: 3,000 hours per ASTM B 117</b>	<b>Yes</b>
<b>Weathering: Color Retention, 5-year south Florida sun, per ASTM D 2244 with a maximum 5deltaE change</b>	<b>Yes</b>
<b>Weathering: Chalk resistance, 5-year south Florida sun, per ASTM D 4214 with a max rating of 8</b>	<b>Yes</b>
<b>Weathering: Gloss Retention, 5-year south Florida sun, per ASTM D 523 with a min of 30%</b>	<b>Yes</b>
<b>Weathering: Resistance to Erosion, 5-year south Florida sun, with less than 10% film loss</b>	<b>Yes</b>
<b>Chemical Resistance: Muriatic Acid, Mortar, Nitric Acid, Detergent and Window Cleaner</b>	<b>Yes</b>
<b>Dry Film Hardness per ASTM D 3363 with no rupture</b>	<b>Yes</b>
<b>Adhesion: Dry Adhesion, Wet Adhesion and Boiling Water Adhesion using the cross hatch method with 0% failure</b>	<b>Yes</b>

## Seven Steps to Long-Lasting Furniture: Our Superior Powder-Coating Process

What's responsible for the good looks and durability of all our products? Our seven-step powder-coating process, which is unlike any other in the industry. While other companies also offer powder-coated products, our seven-step process ensures the highest quality and longevity for our products.

### STEP 1—Shot-Blasting to White Metal

First, all of our metal is cleaned to white metal. We strip it to its purest form using our state-of-the-art shot-blast system. This process removes all the impurities from the metal, especially at the weld joints. It's more effective than traditional acid cleaning and also creates a more textured surface, allowing for better adhesion of the powder coat.

### STEP 2—Five-Stage Chemical Pre-Treatment

Next, the metal goes through a five-stage chemical pre-treatment cleaning process. It is etched, rinsed and cleaned to eliminate any residue, then it's sealed—further promoting adhesion and encouraging corrosion prevention.

### STEP 3—Pre-Heating

Prior to coating, the part is pre-heated so that it can be dried, warmed and then sent directly to the spray booth. With the part heated, it draws powder into the joints, corners and hard-to-reach places to ensure complete coating of the entire surface.

### STEP 4—Zinc-Rich Epoxy Coating

After the pre-heating, a Zinc-Rich epoxy powder-coating is applied to provide the highest quality of corrosion control. It works as a prime coat to protect the metal from corrosion before it receives its topcoat.

### STEP 5—Zinc-Rich Epoxy Coating Gel-Cure

Next, the Zinc-Rich epoxy coating is cured to a gel, allowing the polyester topcoat to combine with the Zinc-Rich epoxy, promoting better adhesion.

### STEP 6—AAMA 2604-Compliant Polyester Topcoat

A polyester topcoat is then applied that's specially formulated to meet AAMA 2604 standards for fading, cracking, chalking, gloss retention, erosion resistance and chemical resistance. No one else in the industry uses this high standard of topcoat. It ensures that our products will maintain their beauty and durability for years to come.

### STEP 7—Final Cure

Finally, the metal goes through a cure oven, which hardens the topcoat and completes the integrated bonding between the Zinc-Rich epoxy and AAMA 2604-Compliant Polyester Topcoat.

**assembly procedures:** IMPORTANT: Assemblers should be reasonably skilled in the assembly of commercial grade/heavy duty fabricated steel equipment.

To ensure proper assembly, it is suggested that you take adequate time to locate and identify each part. To prevent scratching of the finished pieces, we recommend this unit to be assembled on a clean, flat, solid, surface with a drop cloth, allowing plenty of working room. Also please read the instructions and study the sketches very carefully. A little extra time spent before assembly will be well worth it in performing a complete, proper assembly. Please note that all parts have been pre-cut and pre-drilled.

During the assembly process leave all bolts and nuts "finger tight", until the entire unit is completely assembled. This allows room for movement to level or adjust all seats, tops, benches, framework and braces if necessary. After final adjustment and leveling, permanently tighten all nuts, bolts and fasteners. Glides are not to be used when surface mounting the unit.

76

**BRK538I – FOLLOW STEP 1**

**Serpentine Bike Rack – Inground**

**STEP 1**

Lay (BRK538I) Serpentine Bike Rack on its side and attach the inground extensions to both sides. Be sure the extensions are tight and there are no gaps where the tubes mate.

**ALL OTHER INGROUND MODELS – SKIP STEP 1**

**STEP 2**

Locate and prepare the installation site by digging two foundation holes in accordance with your local building code. Raise bike rack to its upright position and place the legs in the footing holes. Block the bike rack as shown in, FIG. 1, maintaining the proper height both horizontally and vertically.

**STEP 3**

Before pouring the concrete, make sure the bike rack is level horizontally and vertically and holds to the top of the rack dims listed on pages 4–5. Mix the concrete to the manufacturer's instructions and fill the holes. Allow to cure according to concrete manufacturer's instructions.

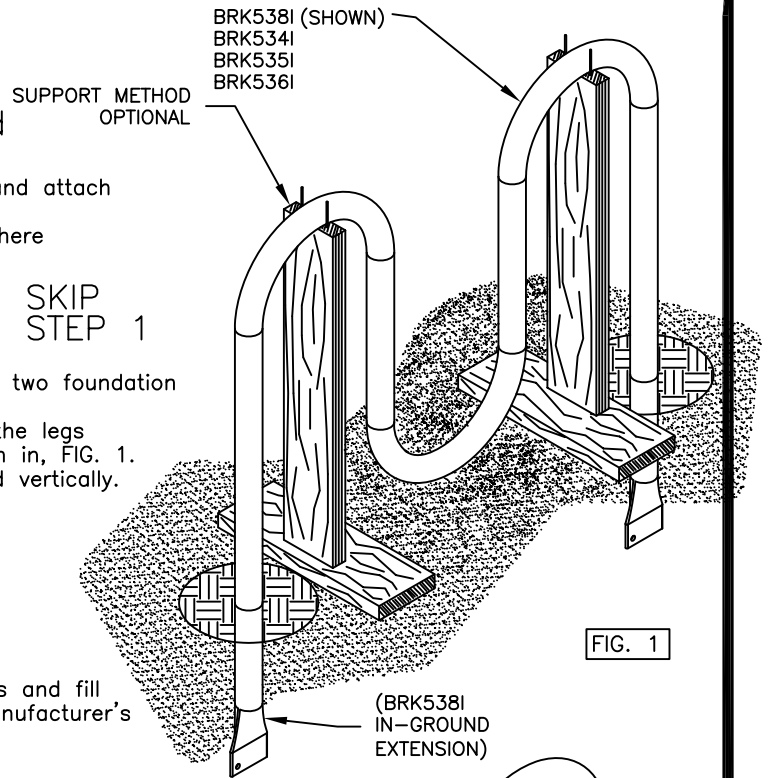

**Serpentine Bike Rack – Surface Mount**

**STEP 1**

Place (BRK538S) Serpentine Bike Rack in its upright position. Determine the location of bike rack and place the foundations securement hardware, (Not Included) in its chosen location.

**STEP 2**

When the foundations securement hardware has been installed, place the unit in its new location and secure to the foundation. See FIG. 2.

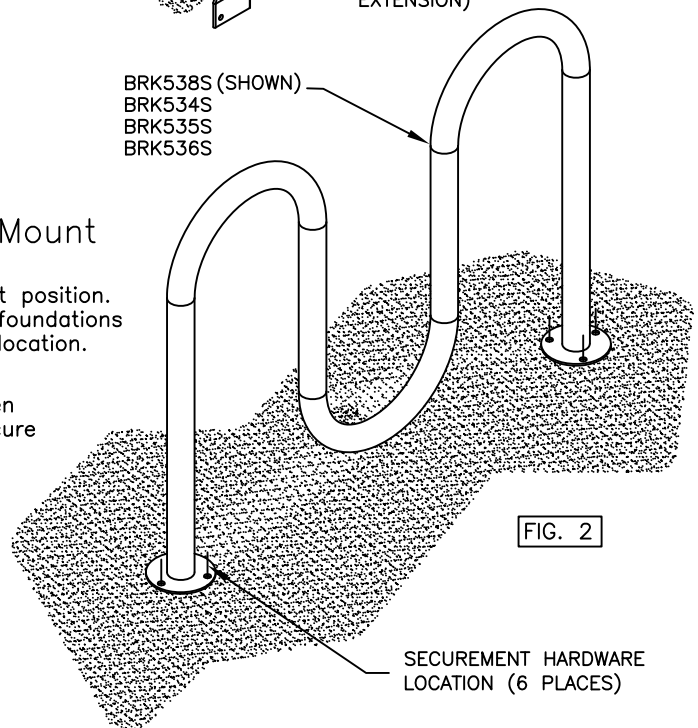

**installation:** WARNING: The proper installation for products may depend upon many factors unique to the site, location, or use of a particular product. Consult with your contractor or other professional to determine your specific installation requirements.

product dimensions:

BRK538I

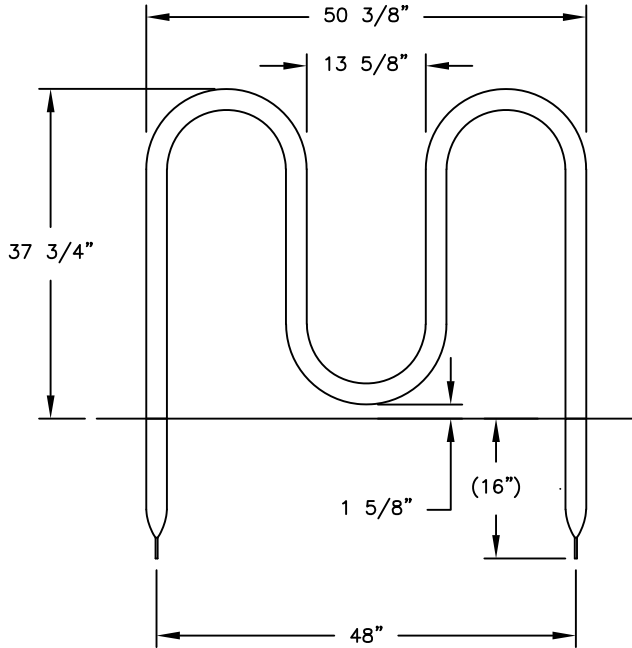

BRK538S

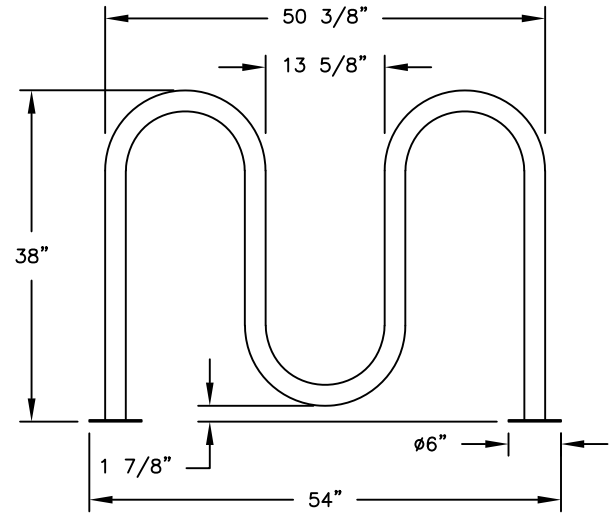

BRK534I

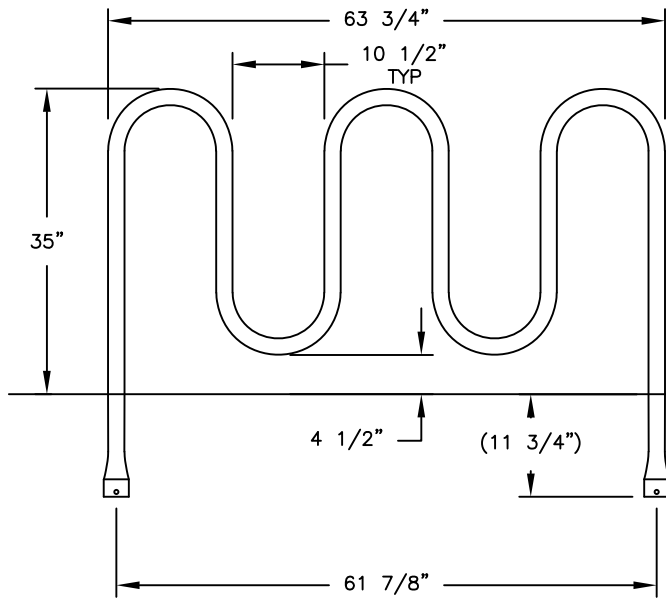

BRK534S

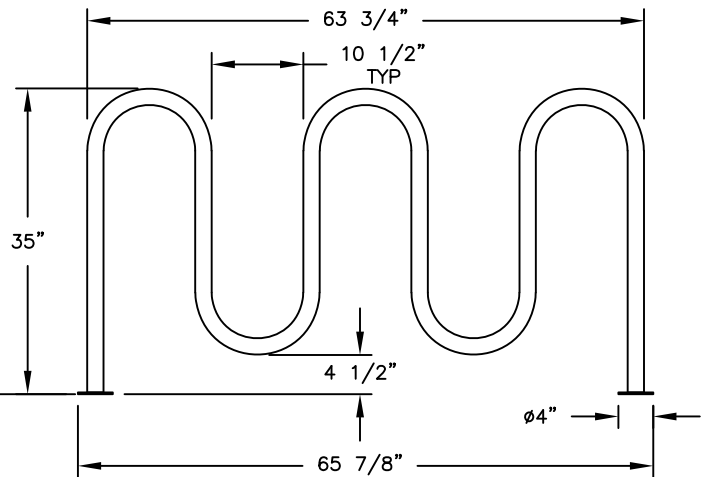

BRK535S

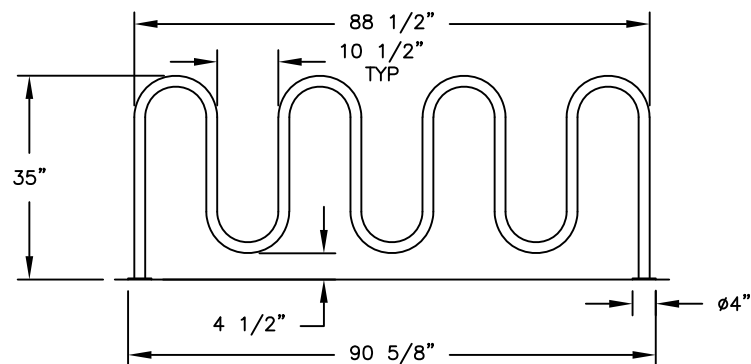

product dimensions:

