

*model no:*

SG151D, SG151P, SG155D,  
SG155P, SG155D-SOLID, SG155DS

**SIGNATURE SERIES**

46" OVAL AND SQUARE AND M.O. 3 SEAT PORTABLE ADA ACCESSIBLE TABLE  
EXPANDED METAL & PERFORATED & SOLID

*customer service:*

**ASSEMBLERS:** If you find any parts missing or damaged, or if you're having difficulty assembling your furniture/equipment, call us at:

\* Before calling, have your product model number available.

1-800-253-8619 (Inside U.S.A.)

260-352-2102 (Outside U.S.A.)

Monday thru Friday,  
8:00 AM - 4:30 PM Eastern Time

(EXCEPT HOLIDAYS)

*maintenance:*

Regular inspection and maintenance of all parts, and fasteners is necessary. Tighten all bolts and nuts. Inspect Tops, Seats, Legs, Braces and Fasteners periodically for wear or vandalism. Replace broken or worn parts immediately or take equipment out of service until repairs are made. Use genuine replacement parts.

To restore plastisol coating to its luster after prolonged use, wash/rinse/dry and use Armor-All ® or similar quality vinyl protectant.

KEEP THIS ASSEMBLY/SPECIFICATION SHEET FOR FUTURE REFERENCE.

*specifications:*

NOTE: We reserve the right to change specifications without notice.

Heat fused poly-vinyl coating, finished on inner-metal structure, to an approximate 3/16" thickness.

Framework assemblies are finished with powder coating; electrostatically applied and oven cured according to powder manufacturer's specifications. Fasteners are stainless steel to resist corrosion.

**TABLE FRAME:**

Main support is constructed of 1 5/8" od x 14 gage structural steel tubing. Mounting brackets on legs are 1/4" x 1 1/4" steel flat bar. Cross brace is constructed of 1" od x 15 gage structural steel tubing. Handicap leg base plate consists of 7 gage steel.

**TOP & SEAT:**

Top and seats use fabricated 3/4" #9 expanded steel mesh. Perforated and Solid Tops use 12 gage sheet metal. Framing for top consists of die formed 14 gage mitred angles 3/4" x 1 3/4". The top's square frame mounting brackets are 1/4" x 3" and 1 1/2" steel flat bar. The seat's mounting brackets are 1/4" x 1 1/2" steel flat bar. The top's standard corner support braces are 1/8" x 1 1/2" strip steel. The top's handicap corner support braces are 1/4" x 1 1/2" steel flat bar. The Solid top mounting brackets are 1/4" x 3" flat bar steel. Corner Support brackets are 10 gage sheet steel.

**GENERAL:**

SG155D and SG155P ground space requirements are 69 1/2" x 74 3/4". The table top is 55 1/2" x 46 3/8" and 30 13/16" to the top of the table. Seats are 10 3/8" wide, 36 1/4" long and 19 11/16" to the top of the seat. Corner radius is 3" to the outside.

SG155D-SOLID ground space requirements are 69 1/2" x 74 3/4". The table top is 55 1/2" x 46" and 30 5/16" to the top of the table. Seats are 10 3/8" wide, 36 1/4" long and 19 11/16" to the top of the seat. Corner radius is 3" to the outside.

SG151D and SG151P ground space requirements are 77" x 78 3/4". The table top is 60 1/2" x 46 3/8" and 30 1/2" to the top of the table. Seats are 10 1/2" wide, 34 3/8" long and 19 5/8" to the top of the seat.

NOTE: When Umbrellas are used on Tables, the Umbrellas must be secured.  
Wabash Valley Umbrellas include an Umbrella Collar for securing.

parts identification:

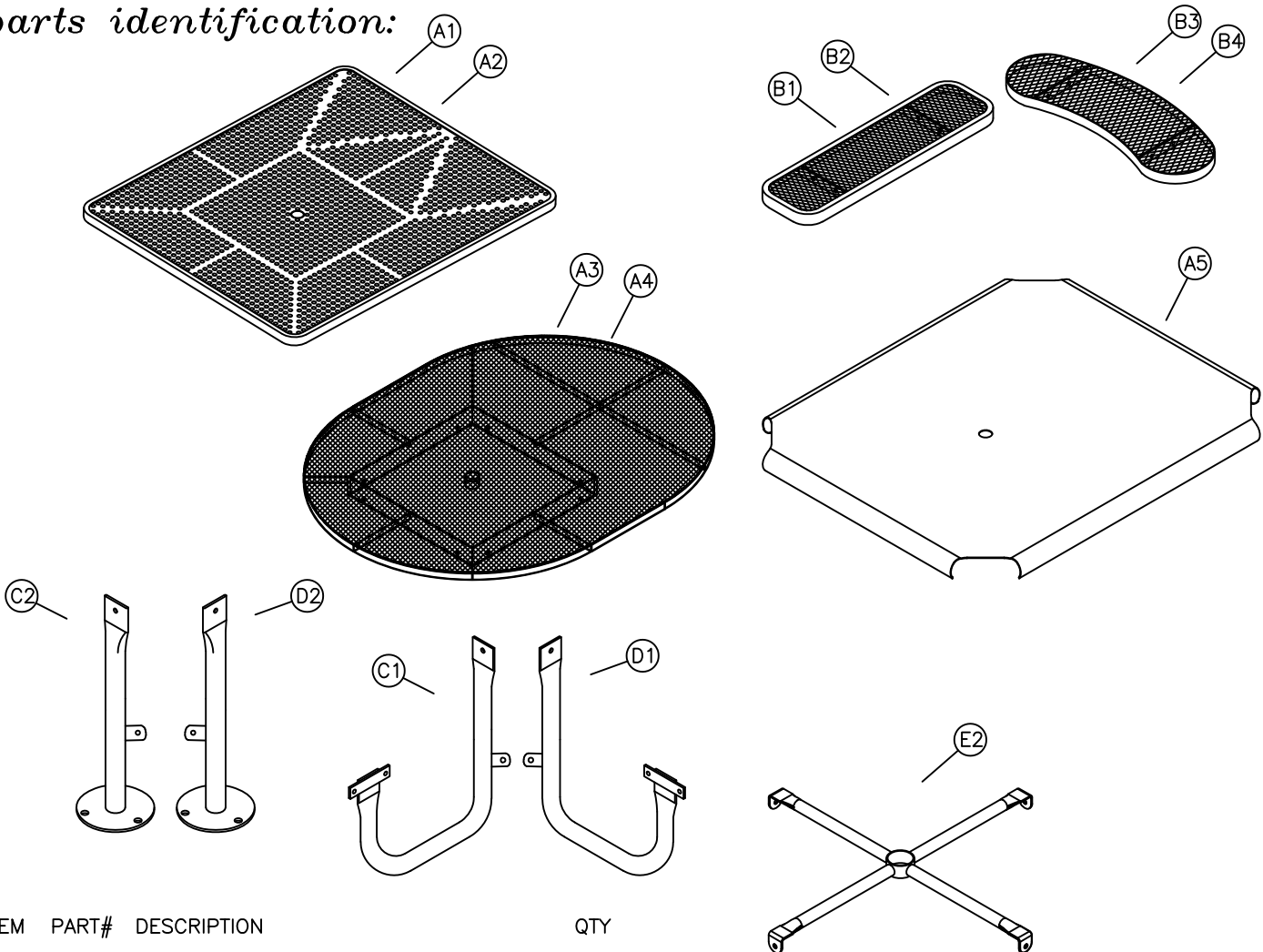

ITEM	PART#	DESCRIPTION	QTY
A1	7706	46" SQUARE X.M. HANDICAP TOP	1
A2	7974	46" SQUARE PERFORATED HANDICAP TOP	1
A3	8196	46" OVAL X.M. HANDICAP TOP	1
A4	8236	46" OVAL PERFORATED HANDICAP TOP	1
A5	4469	46" M.O. SOLID HANDICAP TOP	1
B1	7530R	36" EXPANDED METAL SEAT	3
B2	7998	36" PERFORATED SEAT	3
B3	7666	CONCAVE SEAT - X.M.	3
B4	8000	CONCAVE SEAT - PERFORATED	3
C1	7326	46" RIGHT LEG	3
D1	7327	46" LEFT LEG	3
C2	7070	46" RIGHT HANDICAP LEG	1
D2	7071	46" LEFT HANDICAP LEG	1
E1	7381	46" CROSS BRACE	1
E2	7407	STATE FARM 46" CROSS BRACE	1

hardware identification:

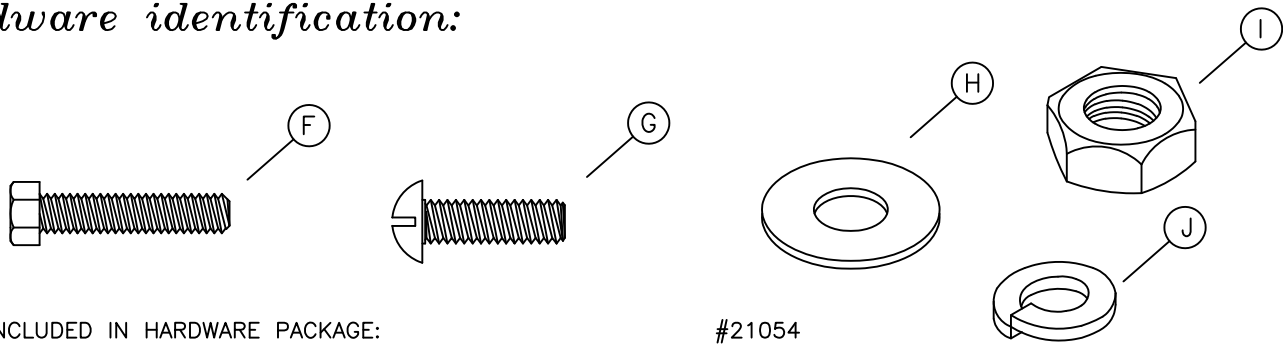

ITEMS INCLUDED IN HARDWARE PACKAGE:

#21054

ITEM	PART#	DESCRIPTION	QTY
F	17011	5/16-18 x 1 1/2" HEX HEAD BOLT - SS	20
G	17088	5/16-18 x 1" TRUSS HEAD MACHINE SCREW - SS	4
H	17028	3/8" FLAT WASHER - SS	48
I	17032	5/16-18 HEX FINISH NUT - SS	24
J	17050	5/16" SPLIT LOCK WASHER - SS	24

ASSEMBLY TOOLS REQUIRED

- 1 - REGULAR TIP SCREWDRIVER
- 2 - 1/2" WRENCHES
- 1 - 3' OR 6' LEVEL

## assembly procedures:

**IMPORTANT:** Assemblers should be reasonably skilled in the assembly of commercial grade/heavy duty fabricated steel equipment.

To ensure proper assembly, it is suggested that you take adequate time to locate and identify each part. To prevent scratching of the finished pieces, we recommend this unit to be assembled on a clean, flat, solid, surface with a drop cloth, allowing plenty of working room. Also please read the instructions and study the sketches very carefully. A little extra time spent before assembly will be well worth it in performing a complete, proper assembly. Please note that all parts have been pre-cut and pre-drilled.

During the assembly process leave all bolts and nuts "finger tight", until the entire unit is completely assembled. This allows room for movement to level or adjust all seats, tops, benches, framework and braces if necessary. After final adjustment and leveling, permanently tighten all nuts, bolts and fasteners. Glides are not to be used when surface mounting the unit.

### STEP 1

Invert the (A-) top so it's upside down on a flat surface. Attach (C1) and (D1) left and right legs to the outside corner of the top's square mounting frame. Attach (D1) and (C2) left and right legs to the opposite corner toward the handicap side, see, FIG. 1. Secure the top end of the legs to the outside of the top's center square mounting frame, using one, per each leg, (F) and (I) using two (H) and one (J) per (F).

**NOTE:** The tabs of each leg should meet at each corner when installing the legs. Temporarily insert one (G), (I), (J) and two (H) loosely into the tab holes of each leg. This allows the legs to secure and hold each other in place at each corner.

Repeat STEP 1 for the other side to complete the installation of all legs. Make sure each leg is properly attached in all four corners of the top's center square mounting frame.

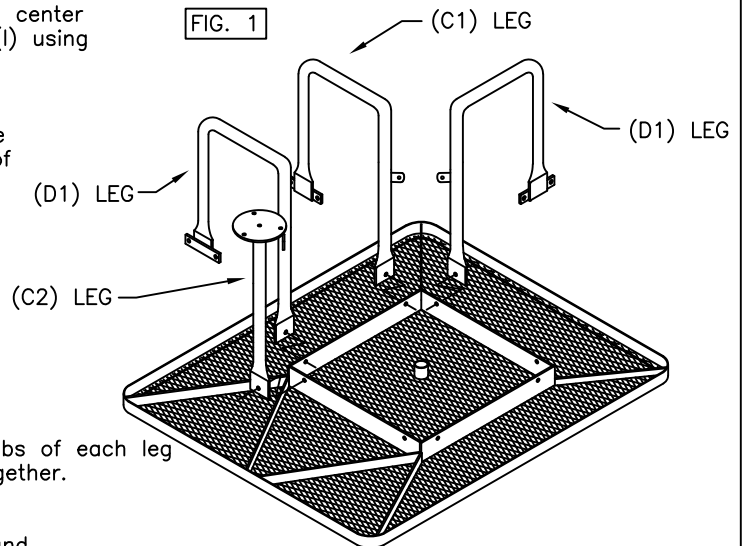

### STEP 2

Attach all four ends of the (E-) cross brace, where the tabs of each leg meet. Use the bolts which temporarily secured each leg together, see FIG. 2.

**NOTE:** Before attaching the cross brace, make sure the round cylinder at the center of the cross brace is pointing downward toward the bottom side of the top.

FIG. 2

### STEP 3

Check all fasteners making sure each fastener is finger tight and properly supporting the unit. Re-invert the table to its' topside up position.

### STEP 4

Lift one (B-) seat above the seat end of each leg, on one side of the unit. Bring the seat down, aligning the mounting brackets, one each leg, to the inside of the seat's mounting brackets, see FIG. 3. Secure the seat using two, per each mounting bracket, (F) and (I) using two (H) and one (J) per (F).

Repeat STEP 4, to attach the remaining seats.

7381 (SHOWN)  
7407

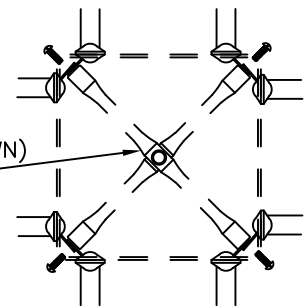

### STEP 5

Level the seats and top, if necessary, and tighten all fasteners with the required tools.

FIG. 3

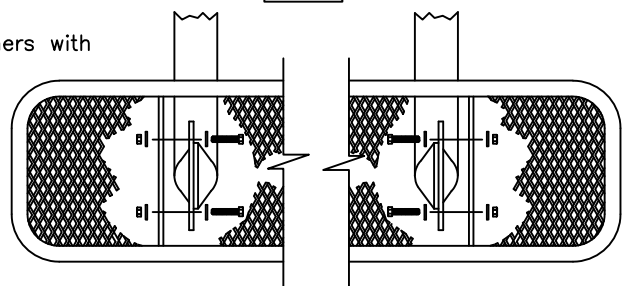

## installation:

**WARNING:** The proper installation for products may depend upon many factors unique to the site, location, or use of a particular product. Consult with your contractor or other professional to determine your specific installation requirements.

product dimensions:

# SG155D, SG155DS, SG155P

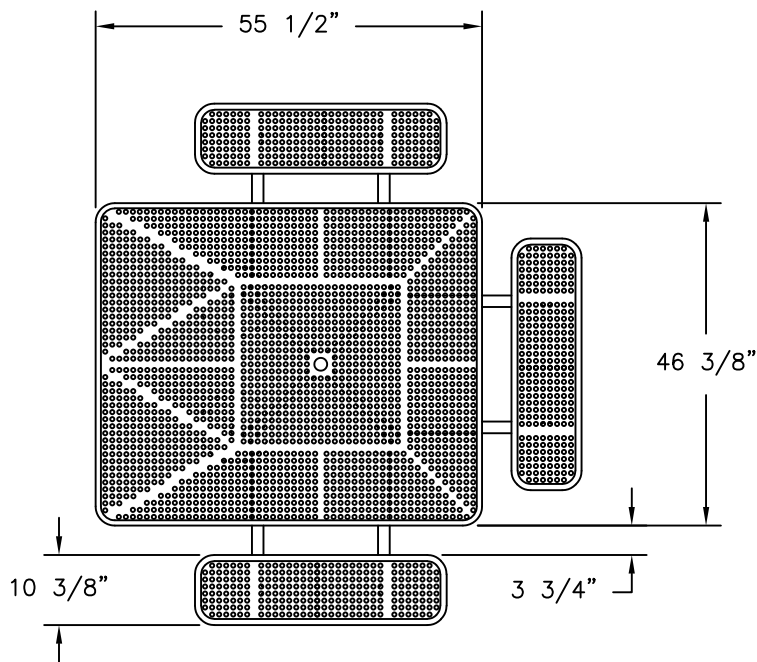
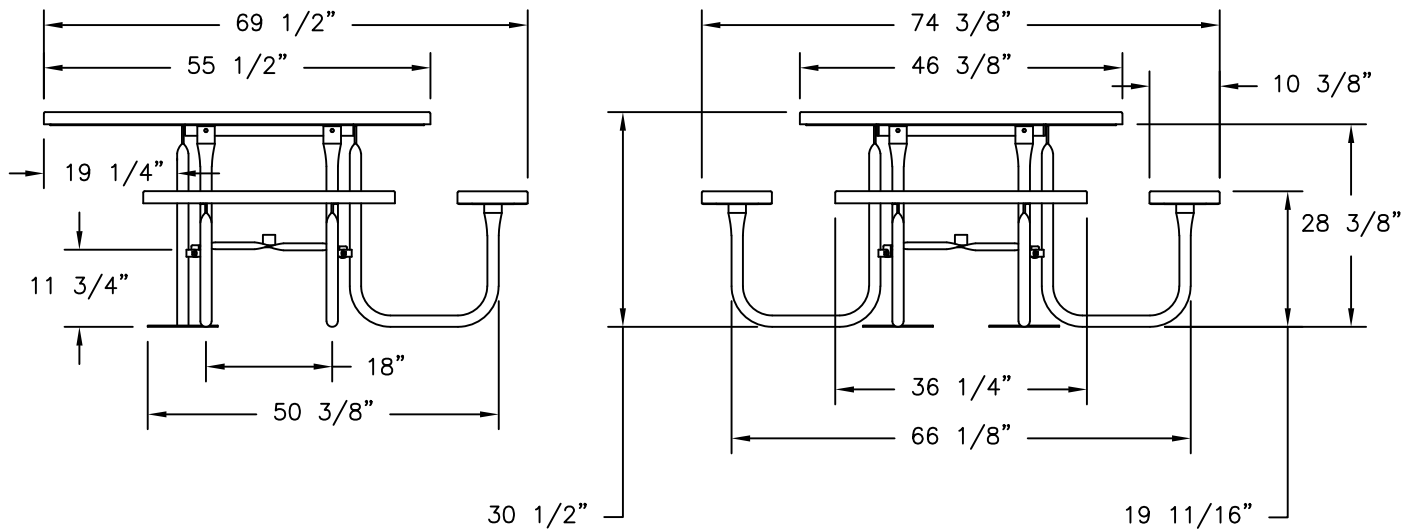

product dimensions:

# SG155D-SOLID

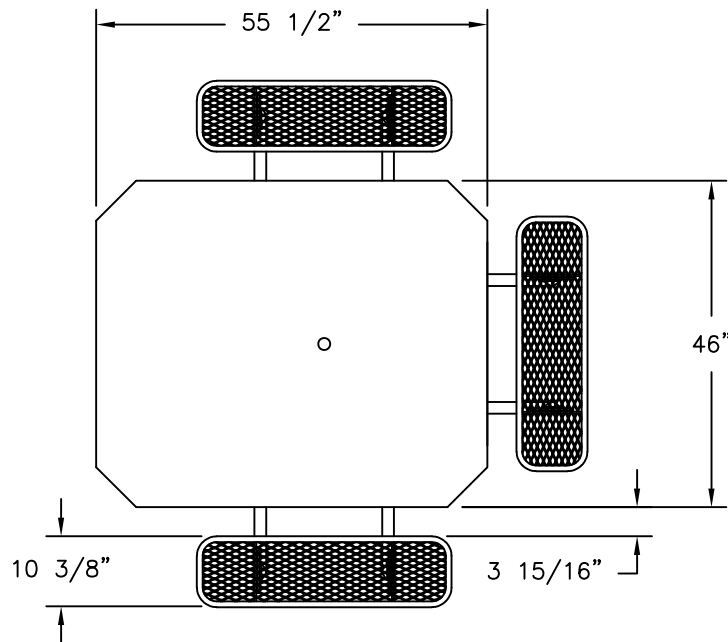
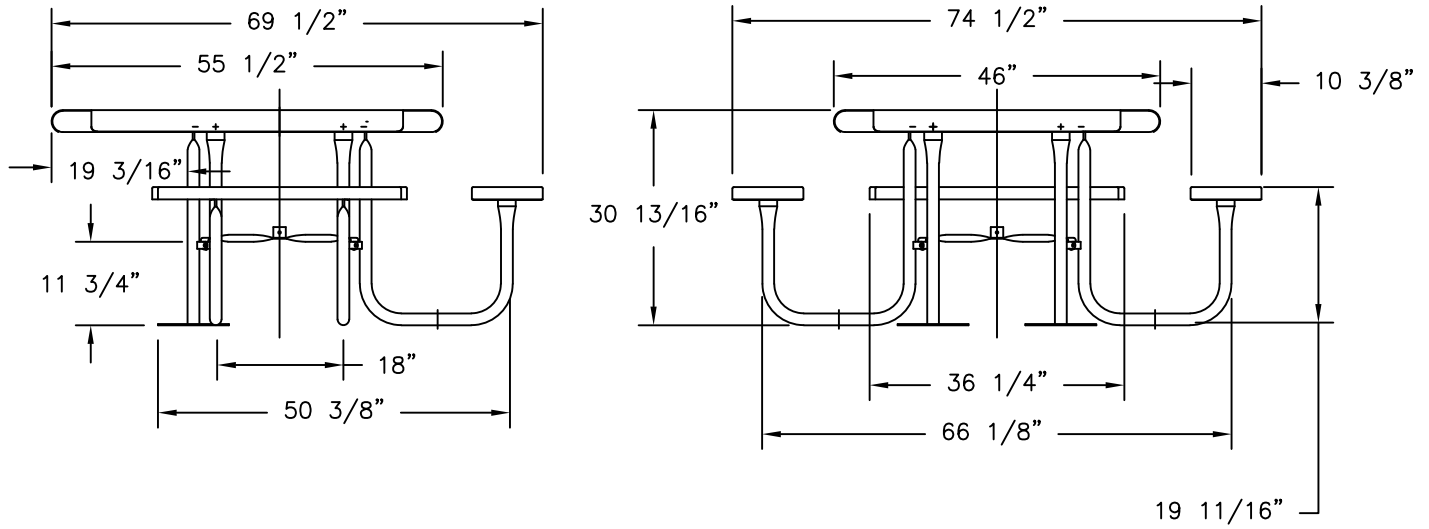

product dimensions:

# SG155D-SOLID

