

model no:

SG105D, SG105P, SG106D, SG106P,
SG110D, SG110P, SG111D, SG111P,
SG120D, SG120P

SIGNATURE SERIES

PORTABLE 6', 8' & 10' LIGHT/HEAVY DUTY
PICNIC TABLES – EXPANDED METAL & PERFORATED

customer service:

ASSEMBLERS: If you find any parts missing or damaged, or if you're having difficulty assembling your furniture/equipment, call us at:

* Before calling, have your product model number available.

1-800-253-8619 (Inside U.S.A.)

260-352-2102 (Outside U.S.A.)

Monday thru Friday,
8:00 AM – 4:30 PM Eastern Time
(EXCEPT HOLIDAYS)

maintenance:

Regular inspection and maintenance of all parts, and fasteners is necessary. Tighten all bolts and nuts. Inspect Tops, Seats, Legs, Braces and Fasteners periodically for wear or vandalism. Replace broken or worn parts immediately or take equipment out of service until repairs are made. Use genuine Wabash Valley replacement parts.

To restore plastisol coating to its luster after prolonged use, wash/rinse/dry and use Armor-All ® or similiar quality vinyl protectant.

KEEP THIS ASSEMBLY/SPECIFICATION SHEET FOR FUTURE REFERENCE.

specifications:

NOTE: We reserve the right to change specifications without notice.

Heat fused poly-vinyl coating, finished on inner-metal structure, to an approximate 3/16" thickness. Framework assemblies are finished with powder coating; electrostatically applied and oven cured according to powder manufacturer's specifications. Fasteners are stainless steel to resist corrosion.

TABLE FRAMES:

Main supports are constructed of 2 3/8" od x 13 gage and 1 5/8" od x 14 gage structural steel tubing. Cross braces are 1" od x 15 gage structural steel tubing. Mounting brackets on legs are 10 gage x 2 7/8" x 6" sheet steel.

TOP & SEATS:

Top and seats use fabricated 3/4-#9 expanded steel mesh and 12 gage sheet metal for perforated. Framing on the 8', 6' tops and 8' and 6' seats are 10 gage mitered angles 3/4" x 1 3/4". The top's center support brace is 1/8" x 1 1/2" strip steel. Top and seat mounting brackets are 1/4" x 1 1/2" steel flat bar.

GENERAL:

10' picnic table ground space requirements are 69 3/4" x 120 3/8". 8' picnic table ground space requirements are 69 3/4" x 96 3/8". 6' picnic table ground space requirements are 69 3/4" x 72 3/8". Table tops are 30 3/8" wide and 29 1/2" to the top of the tables. Seats are 10 3/8" wide and 19 5/8" to the top of the seat. Corner radius is 3" to the outside.

parts identification:

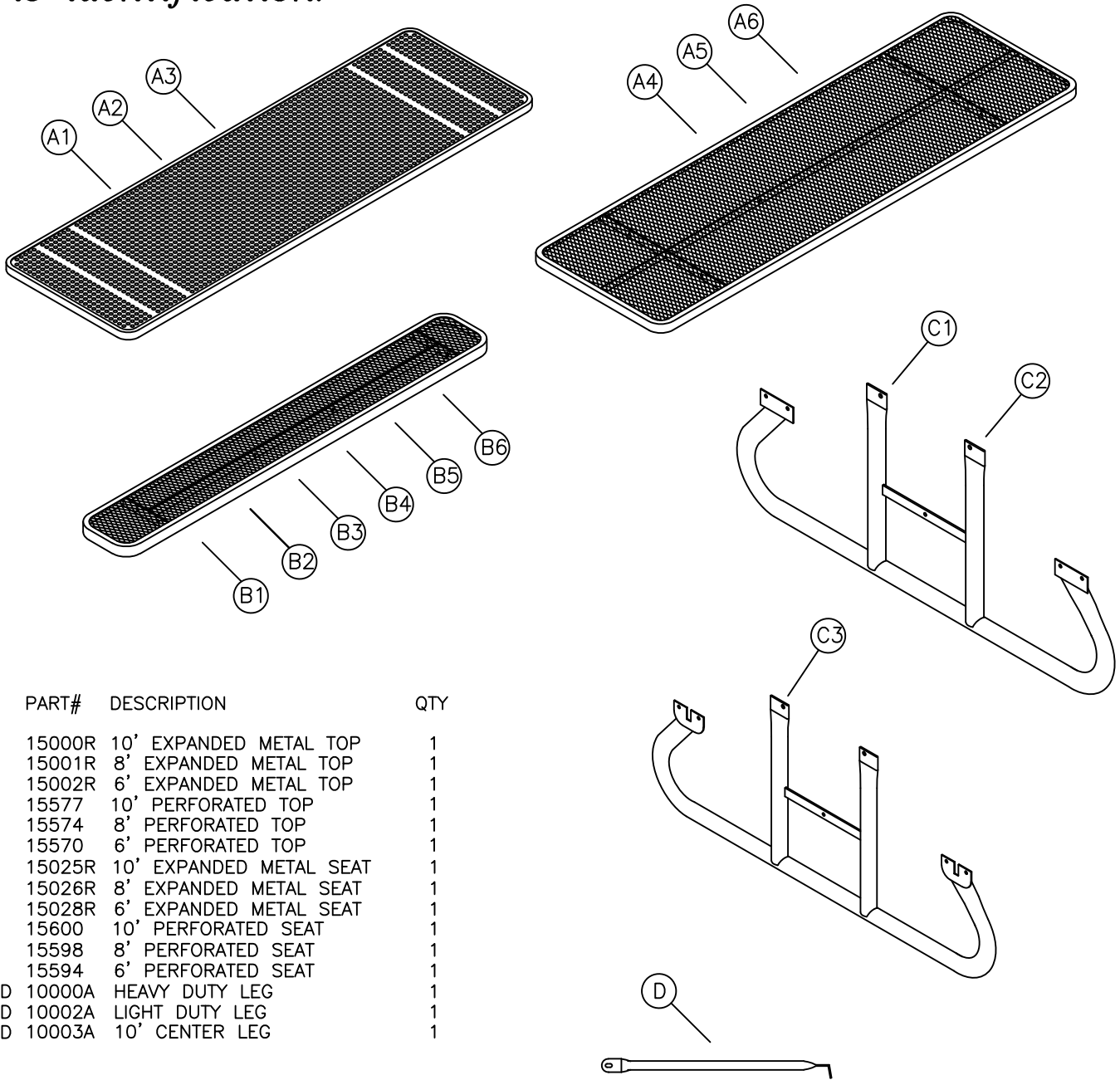

ITEM	PART#	DESCRIPTION	QTY
A1	15000R	10' EXPANDED METAL TOP	1
A2	15001R	8' EXPANDED METAL TOP	1
A3	15002R	6' EXPANDED METAL TOP	1
A4	15577	10' PERFORATED TOP	1
A5	15574	8' PERFORATED TOP	1
A6	15570	6' PERFORATED TOP	1
B1	15025R	10' EXPANDED METAL SEAT	1
B2	15026R	8' EXPANDED METAL SEAT	1
B3	15028R	6' EXPANDED METAL SEAT	1
B4	15600	10' PERFORATED SEAT	1
B5	15598	8' PERFORATED SEAT	1
B6	15594	6' PERFORATED SEAT	1
C1, D	10000A	HEAVY DUTY LEG	1
C2, D	10002A	LIGHT DUTY LEG	1
C3, D	10003A	10' CENTER LEG	1

hardware identification:

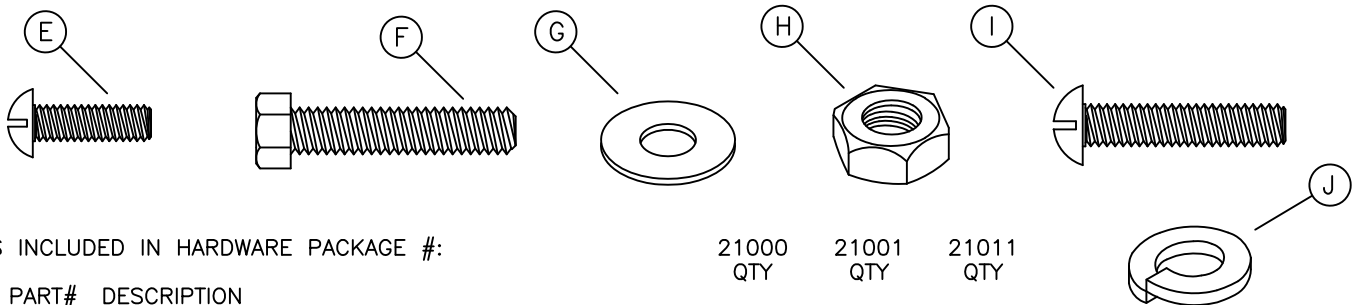

ITEMS INCLUDED IN HARDWARE PACKAGE #:

ITEM PART# DESCRIPTION

ITEM	PART#	DESCRIPTION	21000 QTY	21001 QTY	21011 QTY	
E	17088	5/16-18 x 1" TRUSS HEAD MACHINE SCREW - SS	2	0	2	ASSEMBLY TOOLS REQUIRED
F	17011	5/16-18 x 1 1/2" HEX HEAD BOLT - SS	14	8	6	
G	17028	3/8" FLAT WASHER - SS	32	18	16	
H	17032	5/16-18 HEX FINISH NUT - SS	16	9	8	
I	17025	5/16-18 x 1 1/2" MACHINE SCREW - SS	0	1	0	
J	17050	5/16" SPLIT LOCK WASHER - SS	16	9	8	
						1 - FLAT SCREW DRIVER
						2 - 1/2" WRENCHES
						1 - 3' OR 6' LEVEL

assembly procedures: IMPORTANT: Assemblers should be reasonably skilled in the assembly of commercial grade/heavy duty fabricated steel equipment.

To ensure proper assembly, it is suggested that you take adequate time to locate and identify each part. To prevent scratching of the finished pieces, we recommend this unit to be assembled on a clean, flat, solid, surface with a drop cloth, allowing plenty of working room. Also please read the instructions and study the sketches very carefully. A little extra time spent before assembly will be well worth it in performing a complete, proper assembly. Please note that all parts have been pre-cut and pre-drilled.

During the assembly process leave all bolts and nuts "finger tight", until the entire unit is completely assembled. This allows room for movement to level or adjust all seats, tops, benches, framework and braces if necessary. After final adjustment and leveling, permanently tighten all nuts, bolts and fasteners.

7L

STEP 1: FOR BOTH TABLES WITH AND WITHOUT SEATS.

Invert (A-) top so it's upside down on a flat surface. Attach both (C-) legs to the innermost part of the 8' top end leg mounting brackets with seat mounting brackets toward inside of top, see FIG. 2. If assembling a 10' table, attach both (C-) legs to the outermost part of the 10' top. Attach the center leg at this time with seat mounting brackets toward top center leg mounting bracket, see FIG. 1. Use two, per each leg, (F) and (H) using two (G) and one (J) per each (F).

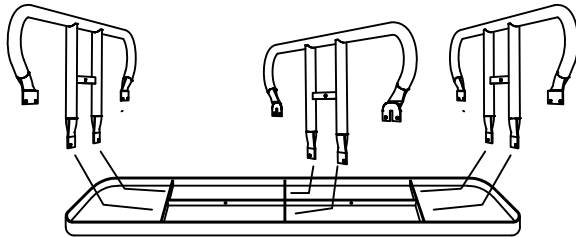

FIG. 1

for 10' picnic table

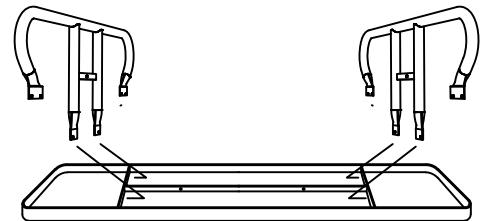

FIG. 2

for 6' and 8' picnic table

Attach one end of each (D) brace to each leg, see FIG. 3, using, per each brace, one (E), two (G), one (J) and one (H). For the 10' table, mount two (D) braces to the center leg using one (I) and (H) and one (J) using two (G).

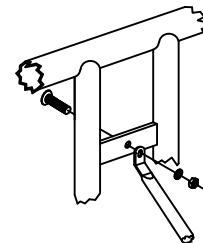
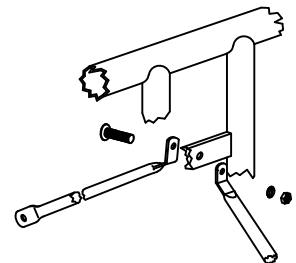

FIG. 3

Secure the opposite end of each brace to the top's center support brace, see FIG. 4, refer to FIG. 1 or 2, using one, per each brace, (F) and (H). Use two (G) and one (J) per each (F).



STEP 2: FOR TABLES WITH SEATS.

Check all fasteners making sure each fastener is finger tight and properly supporting the unit. Re-invert the table to its topside up position.

STEP 3

Attach each (B-) seat to each side of the picnic table, align the seat's mounting brackets with the inside of the leg's mounting brackets, as shown in FIG. 5. Use (F) and (H) using two (G) and one (J) per each (F).

FIG. 5

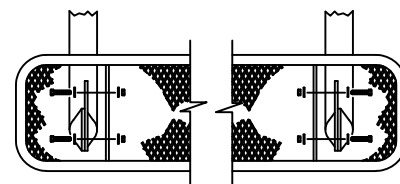
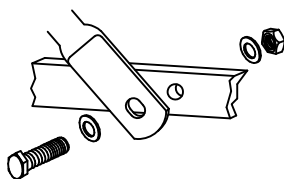

FIG. 4



installation: WARNING: The proper installation for Wabash Valley products may depend upon many factors unique to the site, location, or use of a particular product. Consult with your contractor or other professional to determine your specific installation requirements.

product dimensions:

SG105P/SG106P/SG110P/SG111P

SG105D/SG106D/SG110D/SG111D

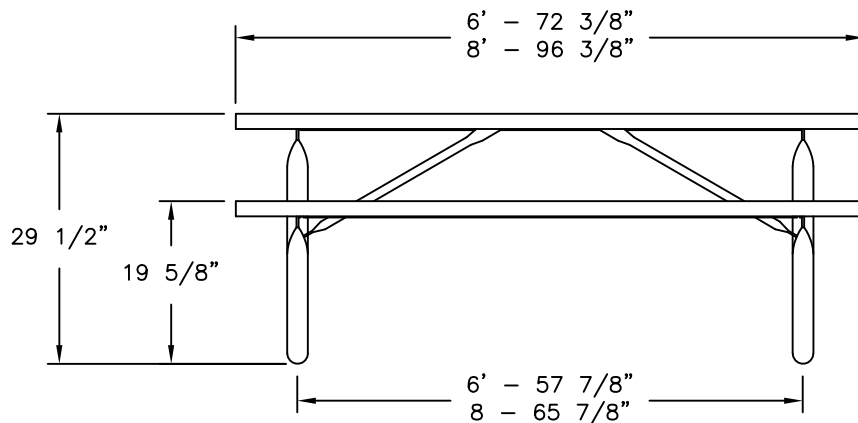

ALL MODELS W/ SEATS

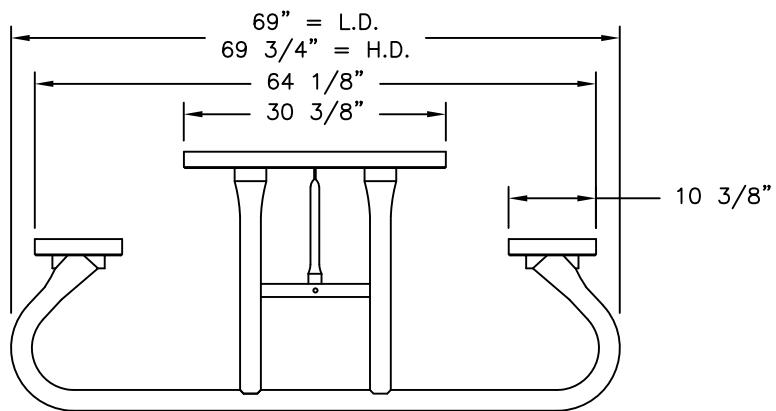

SG120P/SG120D

