

model no:

PP225D, PP225P, PP230D, PP230P,
PP235D, PP235P, PP240D, PP240P

PROFILE/PRESTIGE SERIES

4' & 6' PORTABLE PICNIC TABLES W/ & W/O BACKS
EXPANDED METAL & PERFORATED

customer service:

ASSEMBLERS: If you find any parts missing or damaged, or if you're having difficulty assembling your furniture/equipment, call us at:

* Before calling, have your product model number available.

1-800-253-8619 (Inside U.S.A.)

260-352-2102 (Outside U.S.A.)

Monday thru Friday,

8:00 AM - 4:30 PM Eastern Time

(EXCEPT HOLIDAYS)

maintenance:

Regular inspection and maintenance of all parts, and fasteners is necessary. Tighten all bolts and nuts. Inspect Tops, Seats, Legs, Braces and Fasteners periodically for wear or vandalism. Replace broken or worn parts immediately or take equipment out of service until repairs are made. Use genuine Wabash Valley replacement parts.

To restore plastisol coating to its luster after prolonged use, wash/rinse/dry and use Armor-All ® or similar quality vinyl protectant.

KEEP THIS ASSEMBLY/SPECIFICATION SHEET FOR FUTURE REFERENCE.

specifications:

NOTE: We reserve the right to change specifications without notice.

Heat fused poly-vinyl coating, finished on inner-metal structure, to an approximate 3/16" thickness.

Framework assemblies are finished with powder coating; electrostatically applied and oven cured according to powder manufacturer's specifications. Fasteners are stainless steel to resist corrosion.

TABLE FRAME:

Main supports are constructed of 2 3/8" od x 12 gage galvanized structural steel tubing. Mounting brackets, on legs, are 1/4" plate.

TOP & SEAT:

Expanded tops and seats use fabricated 3/4" #9 expanded steel mesh. The perforated tops and seats uses 12 gage sheet metal. All types of fabricated metals are machine rolled, forming the top's rolled sides and the seat's contour shape. The top and seat's frame/mounting brackets are 10 gage sheet steel. The top's center support brace, running the length of the top, is 1/4" x 1 1/2" steel flat bar. The ends of the rolled sides, of the top and seat, use a 1/2" diameter steel rod, to add support. The seat uses a 1/4" x 1 1/2" steel flat bar for added support, on the underside of the seat's crease, in the contour shape.

GENERAL:

Ground space requirements for 4' tables with benches are 79 1/2" x 48 1/8", 6' tables with benches are 79 1/2" x 72 1/8". The benches are 17 1/8" to the highest part in the seat and 30 1/8" to the top of the table.

Ground space requirements for 4' picnic tables are 62 3/8" x 48 1/8", 6' picnic tables are 62 3/8" x 72 1/8". The benches are 18 1/4" to the highest part in the seat and 30 1/8" to the top of the table.

parts identification:

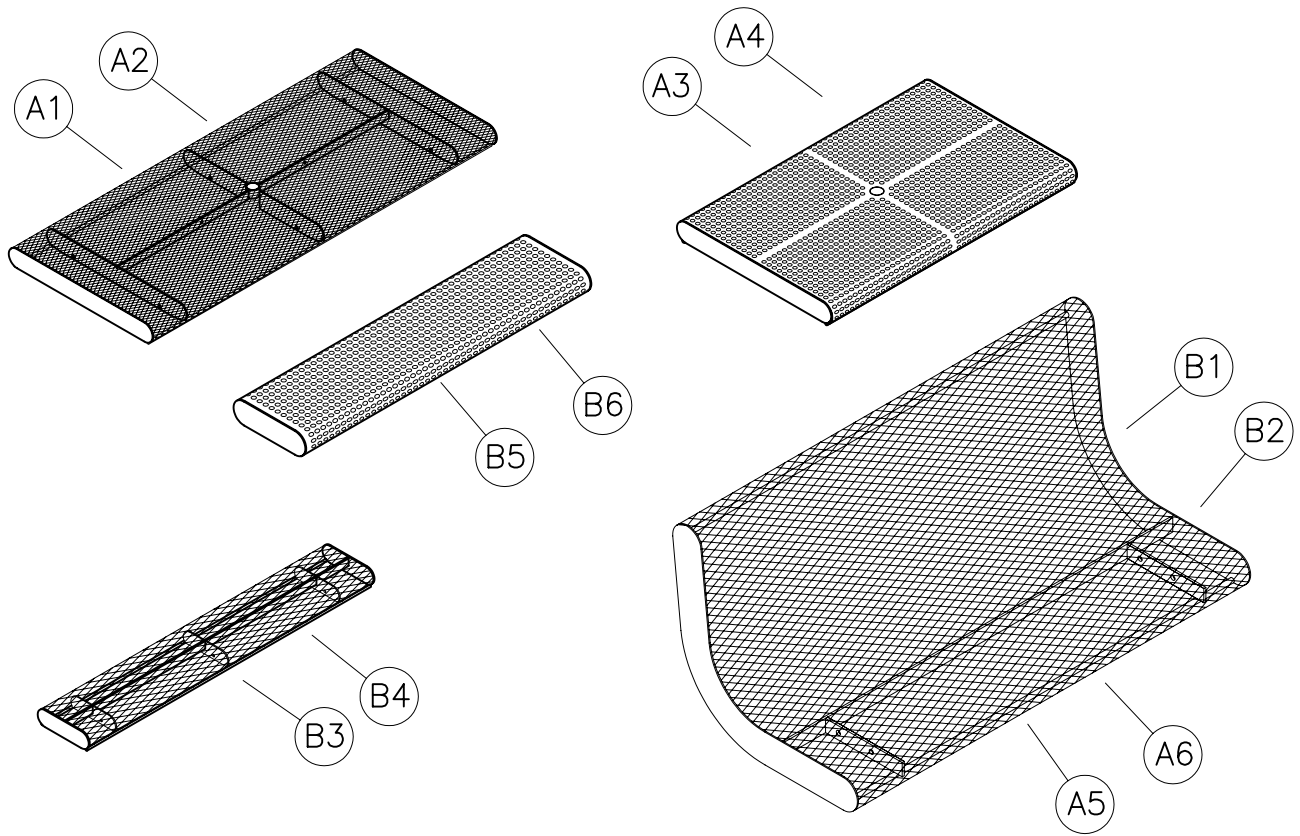

ITEM	PART#	DESCRIPTION	QTY
A1	7510	4' EXPANDED METAL TOP	1
A2	7507	6' EXPANDED METAL TOP	1
A3	7990	4' PERFORATED TOP	1
A4	7989	6' PERFORATED TOP	1
A5	8125	4' EXPANDED METAL BENCH	2
A6	8128	6' EXPANDED METAL BENCH	2
B1	8127	4' PERFORATED BENCH	2
B2	8130	6' PERFORATED BENCH	2
B3	7640	4' EXPANDED METAL SEAT	2
B4	7546	6' EXPANDED METAL SEAT	2
B5	8008	4' PERFORATED SEAT	2
B6	8007	6' PERFORATED SEAT	2
C	7408	CONTOUR TABLE LEG	4
D1	7393	6' CONTOUR TABLE BRACE	2
D2	7393A	4' CONTOUR TABLE BRACE	2

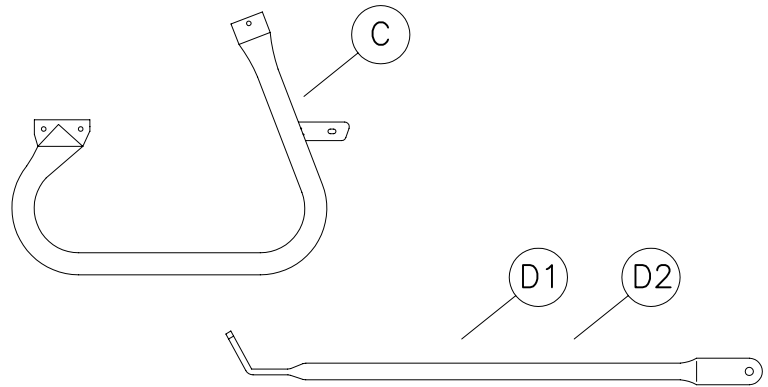

hardware identification:

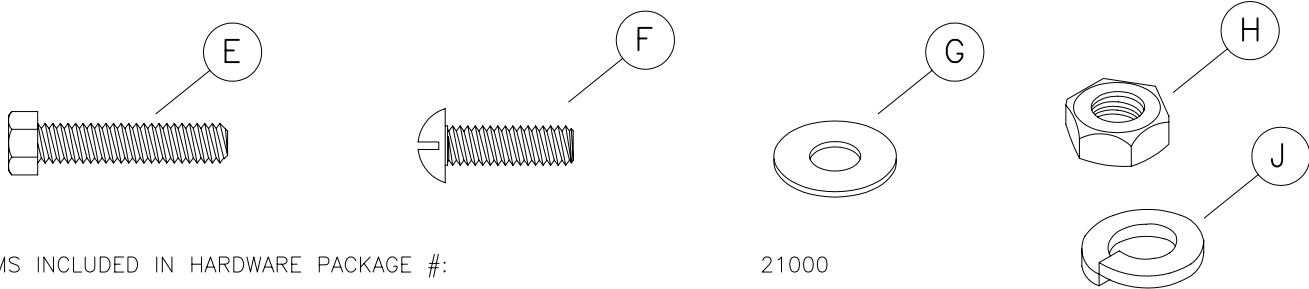

ITEMS INCLUDED IN HARDWARE PACKAGE #:

21000

ITEM	PART#	DESCRIPTION	QTY
E	17011	5/16-18 x 1 1/2" HEX BOLT - SS	14
F	17088	5/16-18 x 1" TRUSS HEAD MACHINE SCREW - SS	2
G	17028	3/8" FLAT WASHER - SS	32
H	17032	5/16-18 HEX FINISH NUT - SS	16
J	17050	5/16" SPLIT LOCK WASHER - SS	16

ASSEMBLY TOOLS REQUIRED

- 1 - REGULAR TIP SCREWDRIVER
- 2 - 1/2" WRENCHES
- 1 - 3' OR 6' LEVEL

assembly procedures: IMPORTANT: Assemblers should be reasonably skilled in the assembly of commercial grade/heavy duty fabricated steel equipment.

To ensure proper assembly, it is suggested that you take adequate time to locate and identify each part. To prevent scratching of the finished pieces, we recommend this unit to be assembled on a clean, flat, solid, surface with a drop cloth, allowing plenty of working room. Also please read the instructions and study the sketches very carefully. A little extra time spent before assembly will be well worth it in performing a complete, proper assembly. Please note that all parts have been pre-cut and pre-drilled.

During the assembly process leave all bolts and nuts "finger tight", until the entire unit is completely assembled. This allows room for movement to level or adjust all seats, tops, benches, framework and braces if necessary. After final adjustment and leveling, permanently tighten all nuts, bolts and fasteners.

7L

STEP 1

Invert the (A-) top upside down on a flat surface. Attach two (C) legs to the inside of mounting brackets on the table with the tabs on each leg facing inward, see FIG. 1. Use one, per leg, (E) and (H) using two (G) and one (J) per (E).

Rotate (C) legs upward. Join the tabs with (D) brace and secure using one (F), (G), (J) and (H). Attach the opposite end of the brace to the top's center support brace, see FIG. 1. Use one (E) and (H) using two (G) and one (J) per each (E).

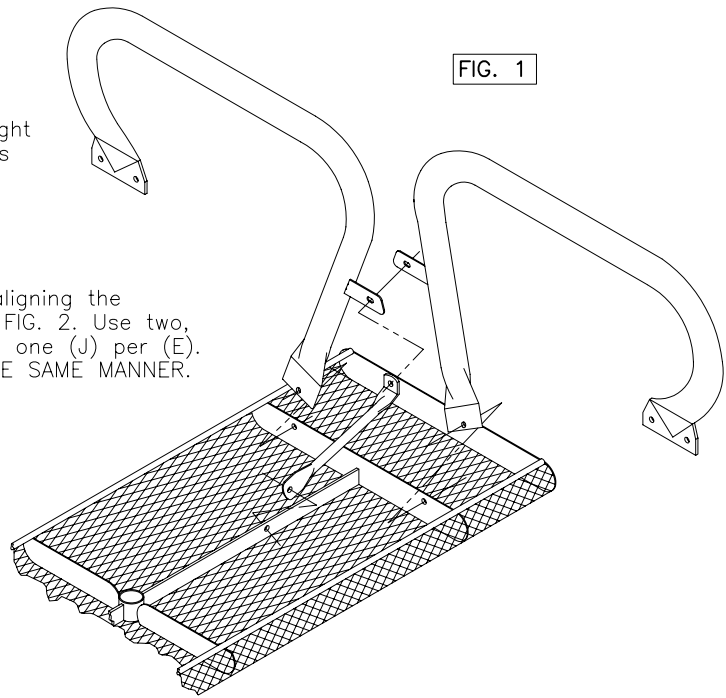

STEP 2

Check all fasteners making sure each fastener is finger tight and properly supporting the unit. Re-invert the table to its topside up position.

STEP 3

Attach both (B-) seats to each side of the picnic table aligning the legs to the inside of mounting brackets on the seat, see FIG. 2. Use two, per each end of the seat, (E) and (H) using two (G) and one (J) per (E). NOTE: WITHOUT BACK IS SHOWN; WITH BACK MOUNTS IN THE SAME MANNER.

STEP 4

Level the seats and top if necessary and tighten all fasteners with wrenches.

FIG. 2

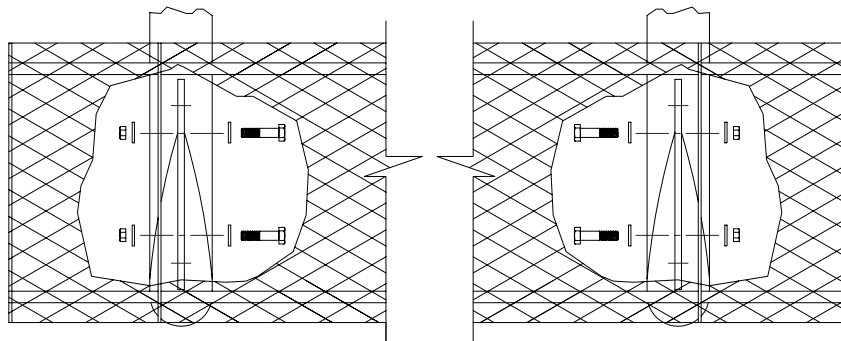

installation: WARNING: The proper installation for Wabash Valley products may depend upon many factors unique to the site, location, or use of a particular product. Consult with your contractor or other professional to determine your specific installation requirements.

product dimensions:

