

Trash Receptacle Series

model no:

GV100G

GV300G

32-Gallon Receptacle – SURFACE MOUNT, INGROUND
PolyTuf® Plastic lumber Custom-Extruded

customer service:

ASSEMBLERS: If you find any parts missing or damaged, or if you're having difficulty assembling your furniture/equipment, call us at:

* Before calling, have your product model number available.

1-800-253-8619 (Inside U.S.A.)

260-352-2102 (Outside U.S.A.)

Monday thru Friday,
8:00 AM – 4:30 PM Eastern Time
(EXCEPT HOLIDAYS)

maintenance:

Regular inspection and maintenance of all parts, and fasteners is necessary. Tighten all bolts and nuts. Inspect Tops, Seats, Legs, Braces and Fasteners periodically for wear or vandalism. Replace broken or worn parts immediately or take equipment out of service until repairs are made. Use genuine Green Valley replacement parts.

KEEP THIS ASSEMBLY/SPECIFICATION SHEET FOR FUTURE REFERENCE.

specifications:

NOTE: We reserve the right to change specifications without notice.

Framework assemblies are finished with powder coating; electrostatically applied and oven cured according to powder manufacturer's specifications. Fasteners are stainless steel to resist corrosion.

RECEPTACLE:

The receptacle's frame bottom is constructed of 10 gage formed sheet steel and 1/8" x 2" strip steel. The frame's top is constructed of 1/8" x 2" strip steel. The planks are made of PolyTuf® Plastic lumber consisting of recycled plastic. The receptacle liner is made of polyethylene.

INGROUND LEG:

The inground tube consists of 2 3/8" diameter x 13 gage structural steel tubing. Tube is welded to support brackets consisting of 1/8" x 2" strip steel and a 1/8" x 2" strip steel band to make up shape.

GENERAL:

32-Gallon Receptacle ground space requirements are 25 7/8" diameter. The overall height is 32".

PolyTuf HDPE plastic lumber is custom-extruded from purified blends of recycle plastics – the kind that come from milk and detergent bottles. PolyTuf plastic lumber is well suited for exterior applications where resistance to weathering and minimal maintenance is required, and a quality appearance is essential. PolyTuf maintains its color stability and finish over its entire service life, and never needs to be sealed, painted or stained.

AAMA 2604-05 Certification

Our seven-step powder-coat system exceeds AAMA 2604-05 (American Architectural Manufacturers Association) test specifications—one of the highest in the industry. Our coating stood up to some of the toughest test specifications, including adhesion, abrasion resistance, chemical resistance, corrosion resistance and fade resistance, to ensure that our products will last longer than anyone else's.

AAMA 2604-05 test Procedures and Performance Requirements

Test Requirements	Compliance
Salt-Spray Resistance: 3,000 hours per ASTM B 117	Yes
Weathering: Color Retention, 5-year south Florida sun, per ASTM D 2244 with a maximum 5deltaE change	Yes
Weathering: Chalk resistance, 5-year south Florida sun, per ASTM D 4214 with a max rating of 8	Yes
Weathering: Gloss Retention, 5-year south Florida sun, per ASTM D 523 with a min of 30%	Yes
Weathering: Resistance to Erosion, 5-year south Florida sun, with less than 10% film loss	Yes
Chemical Resistance: Muriatic Acid, Mortar, Nitric Acid, Detergent and Window Cleaner	Yes
Dry Film Hardness per ASTM D 3363 with no rupture	Yes
Adhesion: Dry Adhesion, Wet Adhesion and Boiling Water Adhesion using the cross hatch method with 0% failure	Yes

Seven Steps to Long-Lasting Furniture: Our Superior Powder-Coating Process

What's responsible for the good looks and durability of all our products? Our seven-step powder-coating process, which is unlike any other in the industry. While other companies also offer powder-coated products, our seven-step process ensures the highest quality and longevity for our products.

STEP 1—Shot-Blasting to White Metal

First, all of our metal is cleaned to white metal. We strip it to its purest form using our state-of-the-art shot-blast system. This process removes all the impurities from the metal, especially at the weld joints. It's more effective than traditional acid cleaning and also creates a more textured surface, allowing for better adhesion of the powder coat.

STEP 2—Five-Stage Chemical Pre-Treatment

Next, the metal goes through a five-stage chemical pre-treatment cleaning process. It is etched, rinsed and cleaned to eliminate any residue, then it's sealed—further promoting adhesion and encouraging corrosion prevention.

STEP 3—Pre-Heating

Prior to coating, the part is pre-heated so that it can be dried, warmed and then sent directly to the spray booth. With the part heated, it draws powder into the joints, corners and hard-to-reach places to ensure complete coating of the entire surface.

STEP 4—Zinc-Rich Epoxy Coating

After the pre-heating, a Zinc-Rich epoxy powder-coating is applied to provide the highest quality of corrosion control. It works as a prime coat to protect the metal from corrosion before it receives its topcoat.

STEP 5—Zinc-Rich Epoxy Coating Gel-Cure

Next, the Zinc-Rich epoxy coating is cured to a gel, allowing the polyester topcoat to combine with the Zinc-Rich epoxy, promoting better adhesion.

STEP 6—AAMA 2604-Compliant Polyester Topcoat

A polyester topcoat is then applied that's specially formulated to meet AAMA 2604 standards for fading, cracking, chalking, gloss retention, erosion resistance and chemical resistance. No one else in the industry uses this high standard of topcoat. It ensures that our products will maintain their beauty and durability for years to come.

STEP 7—Final Cure

Finally, the metal goes through a cure oven, which hardens the topcoat and completes the integrated bonding between the Zinc-Rich epoxy and AAMA 2604-Compliant Polyester Topcoat.

assembly procedures: IMPORTANT: Assemblers should be reasonably skilled in the assembly of commercial grade/heavy duty fabricated steel equipment.

To ensure proper assembly, it is suggested that you take adequate time to locate and identify each part. To prevent scratching of the finished pieces, we recommend this unit to be assembled on a clean, flat, solid, surface with a drop cloth, allowing plenty of working room. Also please read the instructions and study the sketches very carefully. A little extra time spent before assembly will be well worth it in performing a complete, proper assembly. Please note that all parts have been pre-cut and pre-drilled.

During the assembly process leave all bolts and nuts "finger tight", until the entire unit is completely assembled. This allows room for movement to level or adjust all seats, tops, benches, framework and braces if necessary. After final adjustment and leveling, permanently tighten all nuts, bolts and fasteners.

7L

NOTE:

Flat top, Dome top, Solid-bonnet and Ash-bonnet are optional items that set atop the liner. The liner is a standard item and is shown below with the flat top. See FIG 1.

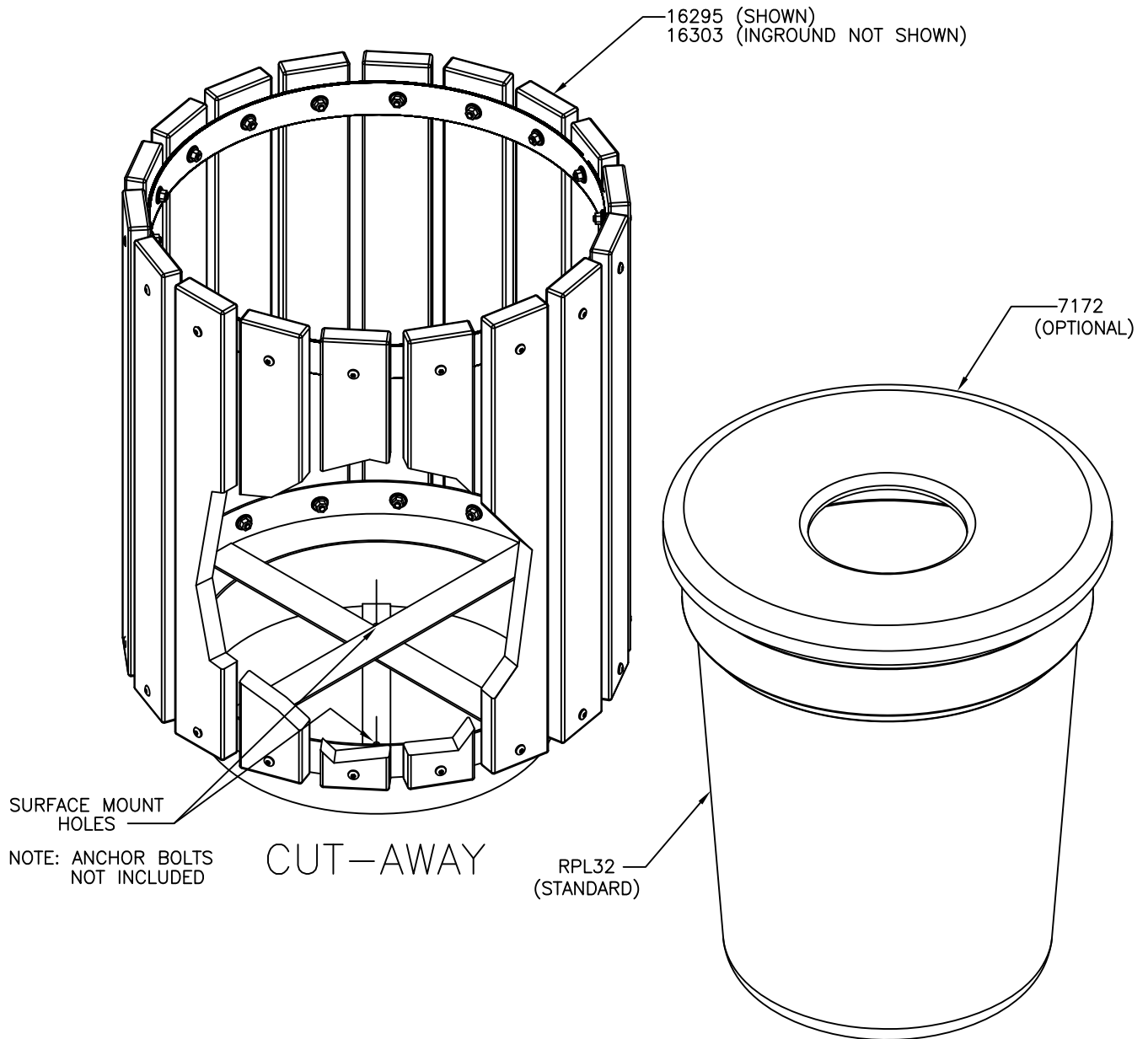

FIG 1

installation: WARNING: The proper installation for Green Valley products may depend upon many factors unique to the site, location, or use of a particular product. Consult with your contractor or other professional to determine your specific installation requirements.

product dimensions:

