

model no:

DS203D, DS103D, DS104D

DESIGNER SERIES

8' HANDICAP PICNIC TABLE FOR THE USFS
PORTABLE, INGROUND & SURFACE MOUNT

customer service:

ASSEMBLERS: If you find any parts missing or damaged, or if you're having difficulty assembling your furniture/equipment, call us at:

* Before calling, have your product model number available.

1-800-253-8619 (Inside U.S.A.)

260-352-2102 (Outside U.S.A.)

Monday thru Friday,

8:00 AM - 4:30 PM Eastern Time

(EXCEPT HOLIDAYS)

maintenance:

Regular inspection and maintenance of all parts, and fasteners is necessary. Tighten all bolts and nuts. Inspect Tops, Seats, Legs, Braces and Fasteners periodically for wear or vandalism. Replace broken or worn parts immediately or take equipment out of service until repairs are made. Use genuine Wabash Valley replacement parts.

To restore plastisol coating to its luster after prolonged use, wash/rinse/dry and use Armor-All ® or similar quality vinyl protectant.

KEEP THIS ASSEMBLY/SPECIFICATION SHEET FOR FUTURE REFERENCE.

specifications:

NOTE: We reserve the right to change specifications without notice.

Heat fused poly-vinyl coating, finished on inner-metal structure, to an approximate 3/16" thickness.

Framework assemblies are finished with powder coating; electrostatically applied and oven cured according to powder manufacturer's specifications. Fasteners are stainless steel to resist corrosion.

TABLE FRAME:

Main support is constructed from a 4" x 4" x 11 gage square and 2 3/8" od x 12 gage round structural steel tubing. The portable leg's seat mounting brackets are 10 gage sheet steel. The top's post mounting bracket and gusset support is 7 gage sheet steel. The seat's post mounting brackets are 1/4" x 1 1/2" steel flat bar. The post's top plates are 4 1/4" x 4 1/4" x 10 ga. sheet steel. The surface mount base plates are 1/4" plate steel. The braces are 1" od x 15 gage structural steel tubing.

TOP & SEAT:

Top and seats use fabricated 3/4" #9 expanded steel mesh. Framing consist of die formed 10 gage mitered angles 3/4" x 4", reinforced with 3/8" x 3" steel flat bar. Top mounting brackets and all internal bracing are 1/4" x 3" steel flat bar. The seat mounting brackets consists of 1/4" x 3" steel flat bar. Seats support braces are 1/4" x 3" steel flat

GENERAL:

DS203D and DS103D ground space requirements are 69 3/4" x 96 3/8". The table top is 30 3/8" wide x 96 3/8" long and 32 3/8" to the top of the table. Seats are 15 3/8" wide x 96 3/8" long and 20 5/8" to the top of the seat.

DS104D ground space requirements are 69 3/4" x 96 3/8". The table top is 30 3/8" wide x 96 3/8" long and 32 3/8" to the top of the table. Seats are 15 3/8" wide x 96 3/8" long and 21 1/4" to the top of the seat.

parts identification:

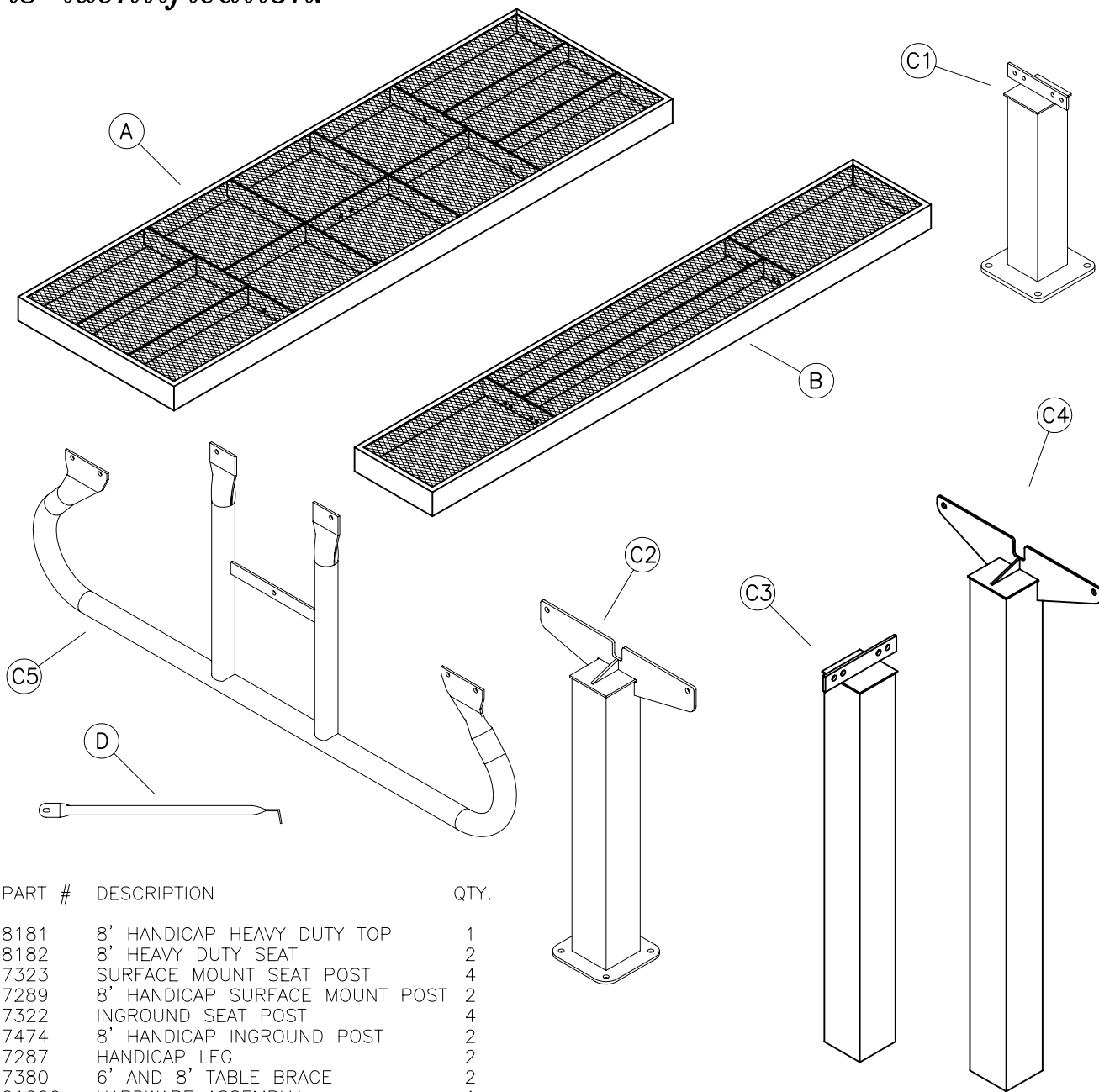

ITEM	PART #	DESCRIPTION	QTY.
A	8181	8' HANDICAP HEAVY DUTY TOP	1
B	8182	8' HEAVY DUTY SEAT	2
C1	7323	SURFACE MOUNT SEAT POST	4
C2	7289	8' HANDICAP SURFACE MOUNT POST	2
C3	7322	INGROUND SEAT POST	4
C4	7474	8' HANDICAP INGROUND POST	2
C5	7287	HANDICAP LEG	2
D	7380	6' AND 8' TABLE BRACE	2
E	21000	HARDWARE ASSEMBLY	1
F	21014	HARDWARE ASSEMBLY	1

hardware identification:

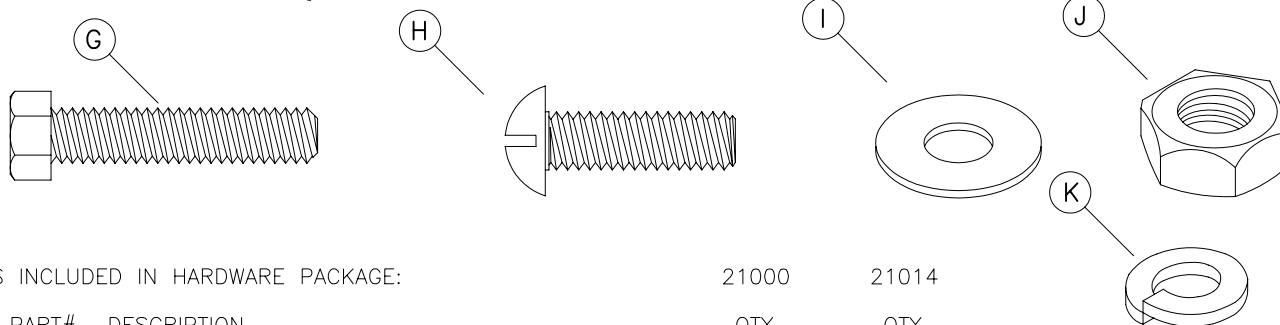

ITEMS INCLUDED IN HARDWARE PACKAGE:

ITEM	PART#	DESCRIPTION	21000 QTY	21014 QTY
G	17011	5/16-18 x 1 1/2" HEX HEAD BOLT - SS	14	4
H	17088	5/16-18 x 1" TRUSS HEAD MACHINE SCREW - SS	2	0
I	17028	3/8" FLAT WASHER - SS	32	8
J	17032	5/16-18 HEX FINISH NUT - SS	16	4
K	17050	5/16" SPLIT LOCK WASHER - SS	16	4

ASSEMBLY TOOLS REQUIRED

- 2 - 1/2" WRENCHES
- 1 - 3' OR 6' LEVEL

assembly procedures: IMPORTANT: Assemblers should be reasonably skilled in the assembly of commercial grade/heavy duty fabricated steel equipment.

To ensure proper assembly, it is suggested that you take adequate time to locate and identify each part. To prevent scratching of the finished pieces, we recommend this unit to be assembled on a clean, flat, solid, surface with a drop cloth, allowing plenty of working room. Also please read the instructions and study the sketches very carefully. A little extra time spent before assembly will be well worth it in performing a complete, proper assembly. Please note that all parts have been pre-cut and pre-drilled.

During the assembly process leave all bolts and nuts "finger tight", until the entire unit is completely assembled. This allows room for movement to level or adjust all seats, tops, benches, framework and braces if necessary. **After final adjustment and leveling, permanently tighten all nuts, bolts and fasteners.**

7L

STEP 1

Invert the (A) top so it's upside down on a flat surface. Attach both of the (C2) or (C4) to the inside of the top's mounting brackets, see FIG. 1. Use two, per each leg, (G) and (J) using two (I) and one (K) per (G). Draw the fasteners to a snug fit with wrenches.

STEP 2

Invert both (B) seats so they're upside down on a flat surface. Attach each (C1) or (C3) legs to the outside of the seat's mounting brackets, see FIG. 2. Use two, per each leg, (G) and (J) using two (I) and one (K) per (G). Draw the fasteners to a snug fit with wrenches.

For Inground unit:

STEP 3

Prepare six foundation holes as shown on page 4. The distance of holes, center to center, are shown in a detailed diagram on page 4 of this assembly instruction sheet.

STEP 4

Re-invert the units to their topside up position and place them in the footing holes. Block the table and seats as shown in FIG. 3.

Before pouring concrete, make sure the table and seats are level horizontally as well as vertically and holds 32" to the top of the table, and 19" to the top of the seats.

Pour concrete to form the footings and let cure for 48 hours.

Tighten all fasteners with wrenches.

For Surface Mount unit:

STEP 3

Prepare and place the foundations securement hardware in its new location. The diagram on page 4 gives a detailed diagram of where the hole locations should be placed.

When the foundation securement hardware has been installed, place the unit in its chosen location and secure to the foundation.

Tighten all fasteners with wrenches.

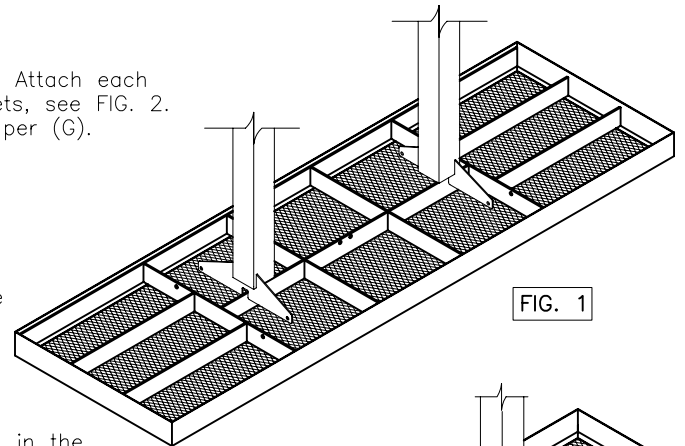

FIG. 1

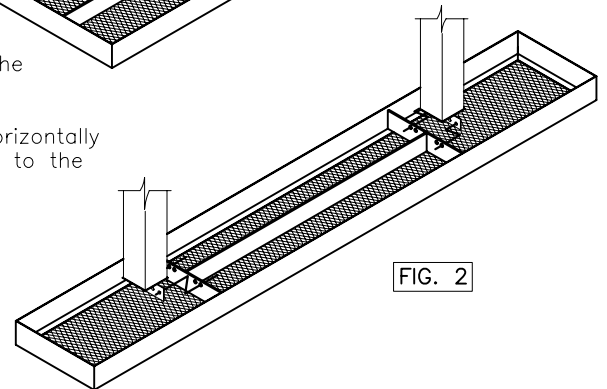

FIG. 2

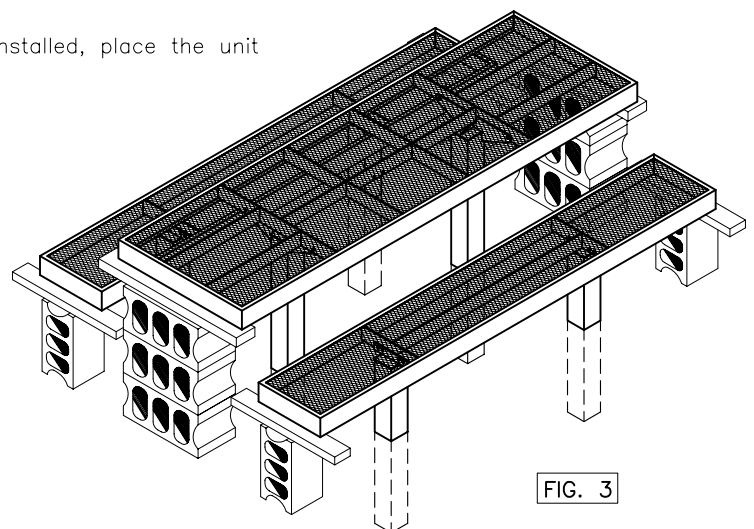
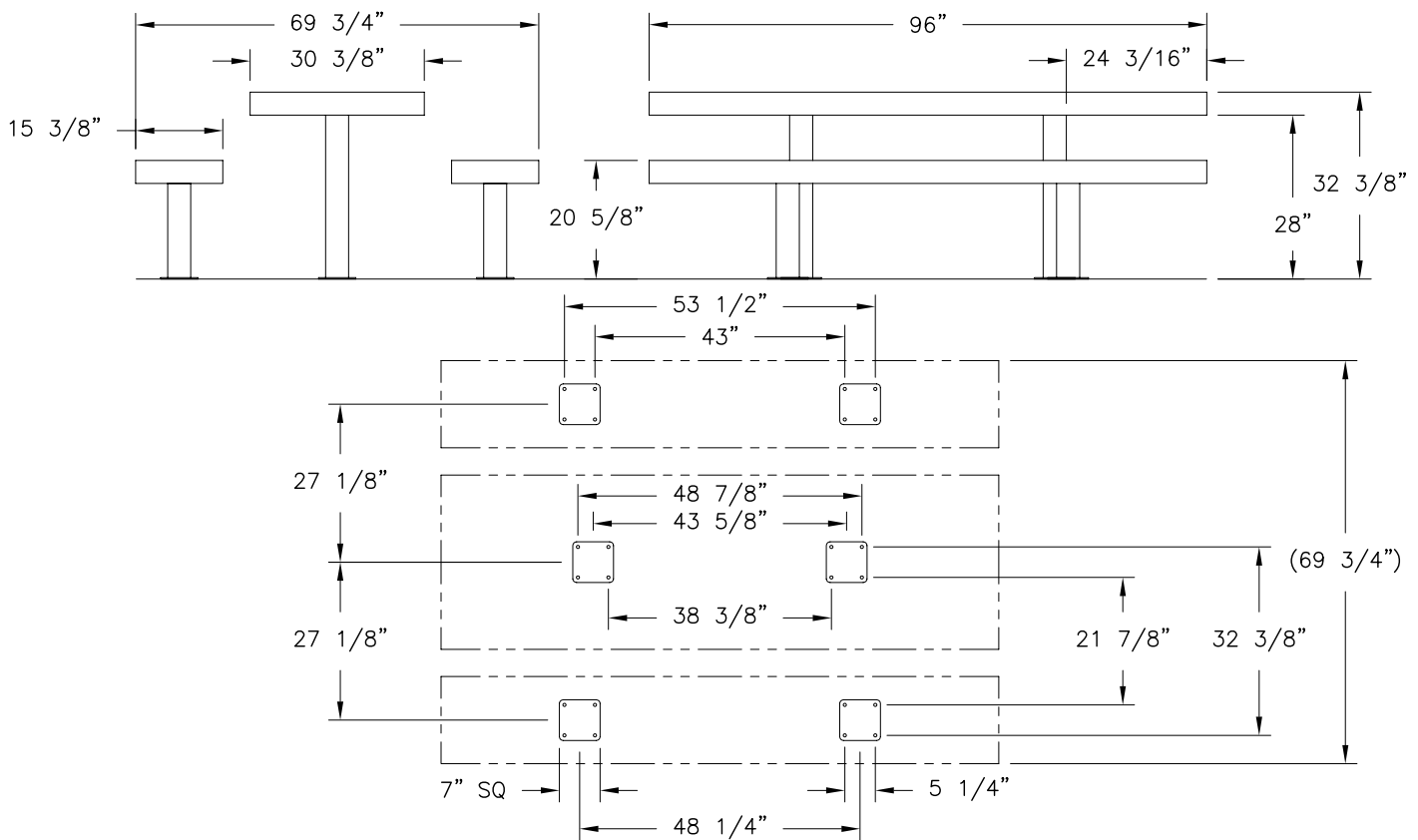
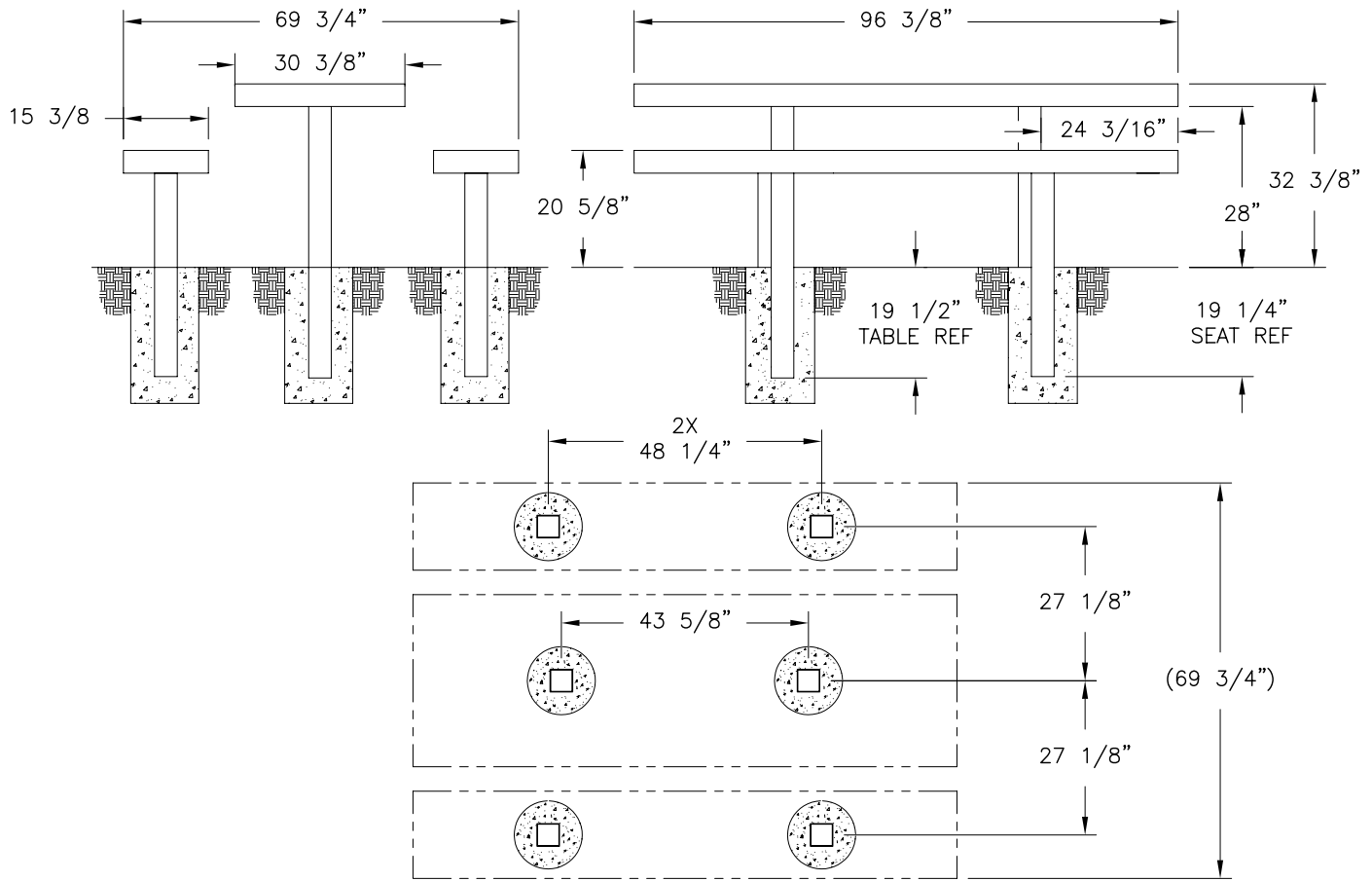

FIG. 3

installation: WARNING: The proper installation for Wabash Valley products may depend upon many factors unique to the site, location, or use of a particular product. Consult with your contractor or other professional to determine your specific installation requirements.

product dimensions:



assembly procedures cont:

STEP 1

Invert the (A) top so it's upside down on a flat surface. Attach the (C5) legs to the outside of the top's mounting brackets, see FIG. 4. Use two per each leg, (G) and (J) using two (I) and one (K) per (G). Draw the fasteners to a snug fit with wrenches.

FIG. 4

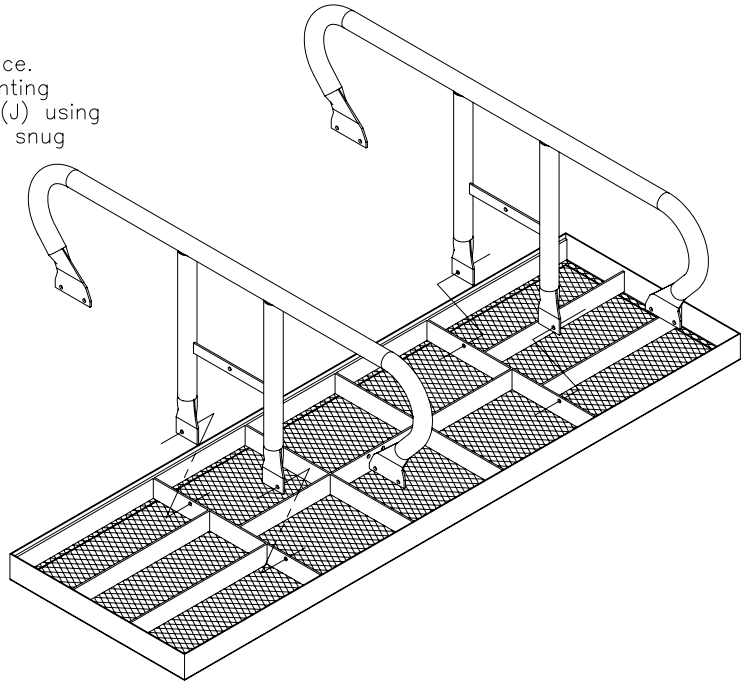

STEP 2

Attach one end of each (D) brace to each leg using one (H), (J), (I) and (K) see FIG. 5. Secure the opposite end of each brace to the top's center support brace see FIG. 6. Use one, per each brace, (G) and (J) using two (I) and one (K) per (G).

STEP 3

Check all fasteners making sure each fastener is finger tight and properly supporting the unit. Re-invert the table to its topside up position.

STEP 4

Attach each (B) seat to each side of the picnic table. Align the seat's mounting brackets with the inside of the leg's mounting brackets, as shown in FIG. 7. Use two (G) and (J) using two (I) and one (K) per (G).

STEP 5

Level both seats and top if necessary. Tighten all fasteners with wrenches.

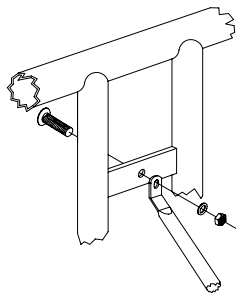

FIG. 5

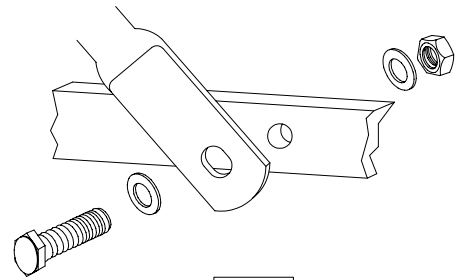
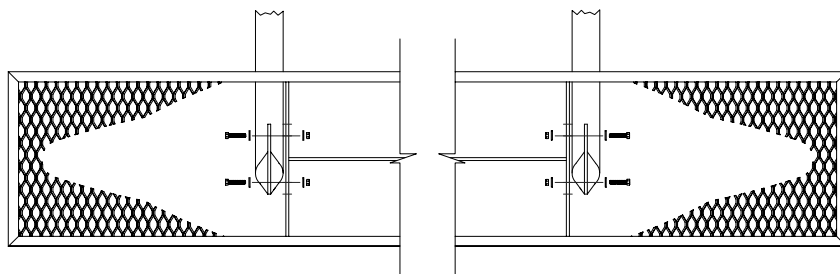

FIG. 6

FIG. 7



product dimensions:

