

model no:

BL100N, BL101N

BIKE RACKS

36" BIKE LOOP
INGROUND AND SURFACE MOUNT

customer service:

ASSEMBLERS: If you find any parts missing or damaged, or if you're having difficulty assembling your furniture/equipment, call us at:

* Before calling, have your product model number available.

1-800-253-8619 (Inside U.S.A.)

260-352-2102 (Outside U.S.A.)

Monday thru Friday,

8:00 AM - 4:30 PM Eastern Time

(EXCEPT HOLIDAYS)

maintenance:

Regular inspection and maintenance of all parts, and fasteners is necessary. Tighten all bolts and nuts. Inspect Tops, Seats, Legs, Braces and Fasteners periodically for wear or vandalism. Replace broken or worn parts immediately or take equipment out of service until repairs are made. Use genuine Wabash Valley replacement parts.

To restore plastisol coating to its luster after prolonged use, wash/rinse/dry and use Armor-All ® or similiar quality vinyl protectant.

KEEP THIS ASSEMBLY/SPECIFICATION SHEET FOR FUTURE REFERENCE.

specifications:

NOTE: We reserve the right to change specifications without notice.

Heat fused poly-vinyl coating, finished on inner-metal structure, to an approximate 3/16" thickness.

Framework assemblies are finished with powder coating; electrostatically applied and oven cured according to powder manufacturer's specifications. Fasteners are stainless steel to resist corrosion.

FRAME:

Bike loops consist of 1/2" x 1 1/2" steel flat bar. The inground bike loops use a 5/16" diameter rod, to add support towards the bottom ends. The carousel bike rack uses 2 7/8" galvanized tube with 5/8-11-UNC stud welded to 1/4" plate welded into frame tube. The surface mount base plate consists of 3/8" plate.

GENERAL:

Ground space requirements for bike loop are 1 3/4" x 25 7/8".

parts identification:

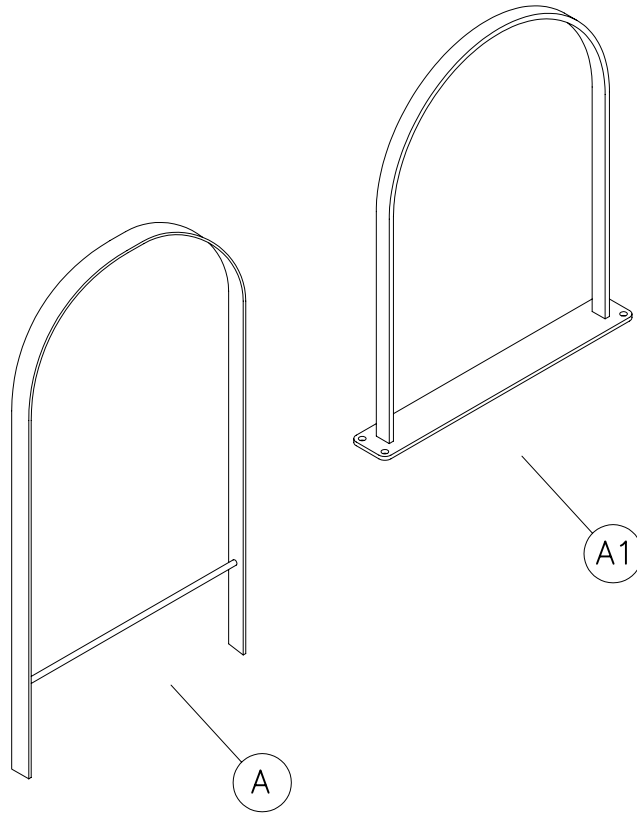

ITEM	PART	DESCRIPTION	QTY.
A	7638	36" BIKE LOOP (INGROUND)	1
A1	8193	36" BIKE LOOP (SURFACE MOUNT)	1

hardware identification:

assembly procedures: IMPORTANT: Assemblers should be reasonably skilled in the assembly of commercial grade/heavy duty fabricated steel equipment.

To ensure proper assembly, it is suggested that you take adequate time to locate and identify each part. To prevent scratching of the finished pieces, we recommend this unit to be assembled on a clean, flat, solid, surface with a drop cloth, allowing plenty of working room. Also please read the instructions and study the sketches very carefully. A little extra time spent before assembly will be well worth it in performing a complete, proper assembly. Please note that all parts have been pre-cut and pre-drilled.

During the assembly process leave all bolts and nuts "finger tight", until the entire unit is completely assembled. This allows room for movement to level or adjust all seats, tops, benches, framework and braces if necessary. After final adjustment and leveling, permanently tighten all nuts, bolts and fasteners.

76

36" BIKE LOOP – Inground

STEP 1

Prepare two foundation holes as shown below.

STEP 2

Place the bike loop in its foundation holes and block as shown in FIG. 1.

Before pouring concrete, make sure the bike loop holds 36" to the top of the bike loop and is level horizontally as well as vertically.

Pour concrete and let cure for 48 hours.

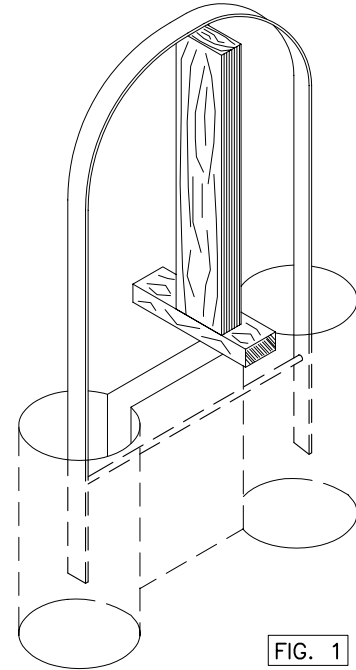

36" BIKE LOOP – Surface Mount

STEP 1

For the surface mount bike rack, determine location and using holes in base plate as a template, drill holes and secure in concrete. See FIG. 2.

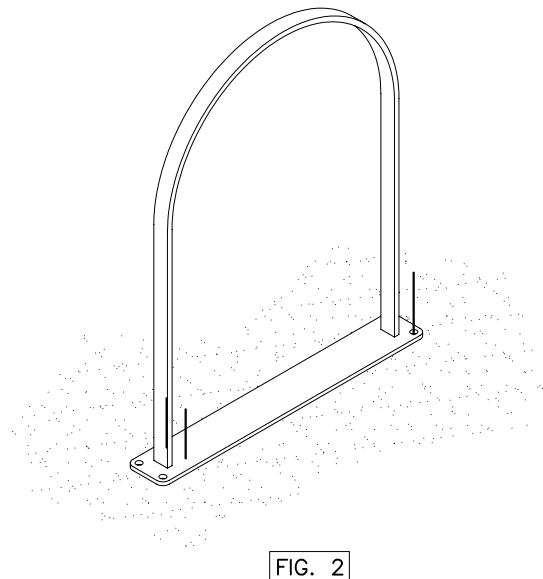

installation: WARNING: The proper installation for Wabash Valley products may depend upon many factors unique to the site, location, or use of a particular product. Consult with your contractor or other professional to determine your specific installation requirements.

product dimensions:

