

model no:



GR103N

WABASH VALLEY

RING GRILL CAMPFIRE W/ STAPLE ANCHORS

© Wabash Valley Manufacturing, Inc.

customer service:

ASSEMBLERS: If you find any parts missing or damaged, or if you're having difficulty assembling your furniture/equipment, call us at:

* Before calling, have your product model number available.

1-800-253-8619 (Inside U.S.A.)

260-352-2102 (Outside U.S.A.)

Monday thru Friday,

8:00 AM - 4:30 PM Eastern Time

(EXCEPT HOLIDAYS)

Any correspondence concerning our product should be sent directly to our Customer Service Manager at:

Wabash Valley Manufacturing, Inc.

505 E. Main Street

P.O.Box 5

Silver Lake, IN 46982 U.S.A.

FAX: 260-352-2160

maintenance:

Regular inspection and maintenance is necessary. Tighten all bolts and nuts. Inspect Braces and Fasteners periodically for wear or vandalism. Replace broken or worn parts immediately or take equipment out of service until repairs are made. Framework assemblies are finished with painted non-toxic, heat and rust-resistant black enamel.

KEEP THIS ASSEMBLY/SPECIFICATION SHEET FOR FUTURE REFERENCE.

specifications:

NOTE: We reserve the right to change specifications without notice.

GRILL:

The grill grate is fabricated of 1/2" steel rod. The handles are made of coil spring steel. The fire box consists of 3/16" thick plate steel. The Staple Anchors are made of 1/2" steel rod. The cross brace on ring is made of 1 1/4" x 1 1/4" x 3/16" angle iron.

GENERAL:

The overall dimensions of the Ring Grill Campfire are: 30 3/8" [772mm] diameter width x 34 5/8" [879mm] deep x 15" [381mm] high.

parts identification:

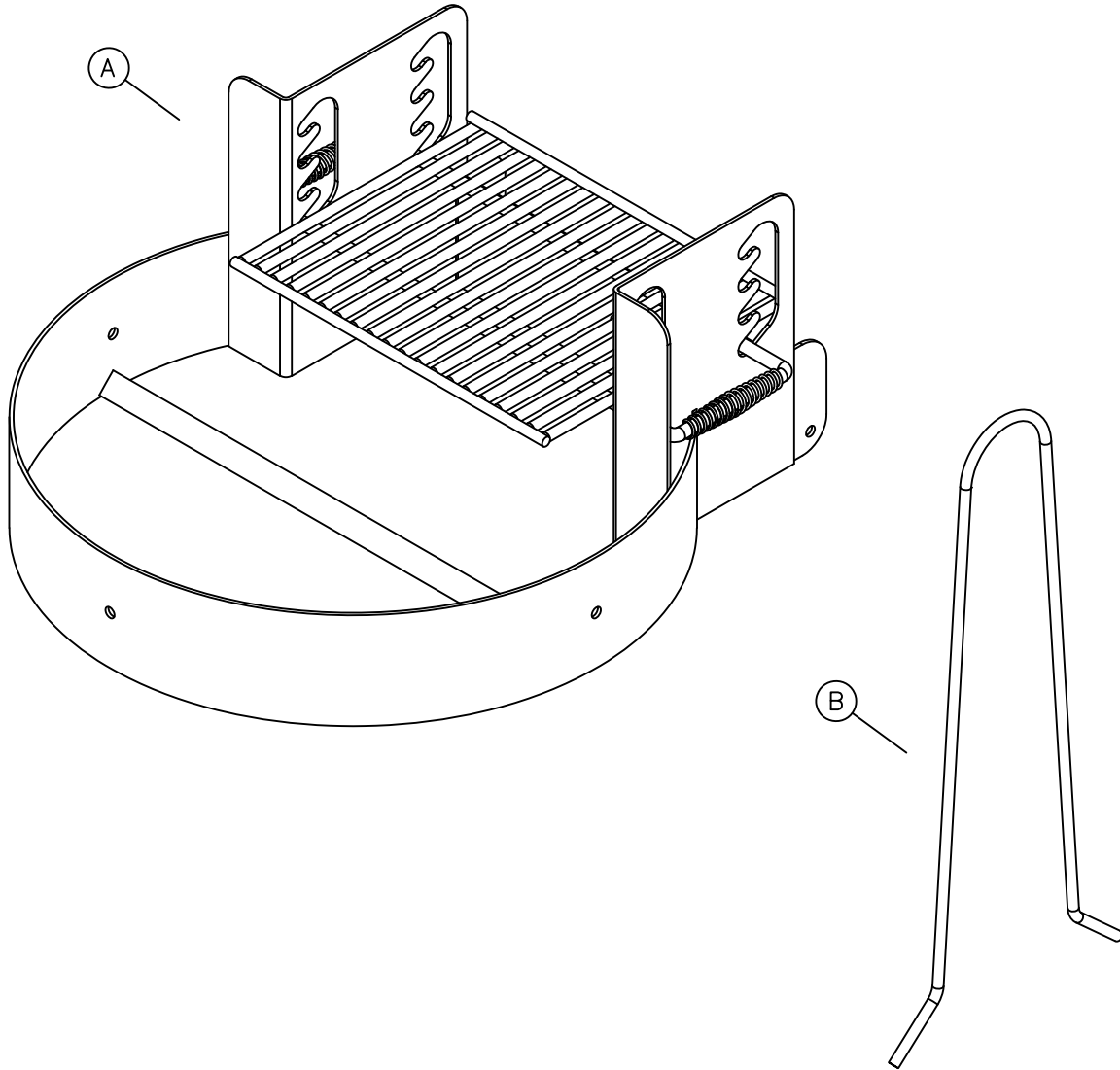

ITEM	PACKAGE#	DESCRIPTION
A, B	AFG80TB	RING GRILL CAMPFIRE W/ STAPLE ANCHORS

hardware identification:

HARDWARE PACKAGE INCLUDED

ASSEMBLY TOOLS REQUIRED

1 - 2' OR 4' LEVEL

assembly procedures: IMPORTANT: Assemblers should be reasonably skilled in the assembly of commercial grade/heavy duty fabricated steel equipment.

To ensure proper assembly, it is suggested that you take adequate time to locate and identify each part. To prevent scratching of the finished pieces, we recommend this unit to be assembled on a clean, flat, solid, surface with a drop cloth, allowing plenty of working room. Also please read the instructions and study the sketches very carefully. A little extra time spent before assembly will be well worth it in performing a complete, proper assembly. Please note that all parts have been pre-cut and pre-drilled.

During the assembly process leave all bolts and nuts "finger tight", until the entire unit is completely assembled. This allows room for movement to level or adjust all framework and braces if necessary. After final adjustment and leveling, permanently tighten all nuts, bolts and fasteners.

76

STEP 1

Lay grill body on its' side and insert staple anchors into holes in tabs, both sides.

STEP 2

Prepare two foundation holes. Depth of hole may vary due to your location and soil type. Refer to local contractors for best results. Set grill up-right and place Staple Anchors into prepared holes. Suspend grill with temporary blocks being sure to hold grill level to ground as shown on page 4.

Before pouring concrete, make sure the grill is level horizontally as well as vertically. Pour concrete to form the footing and let cure for 48 hours.

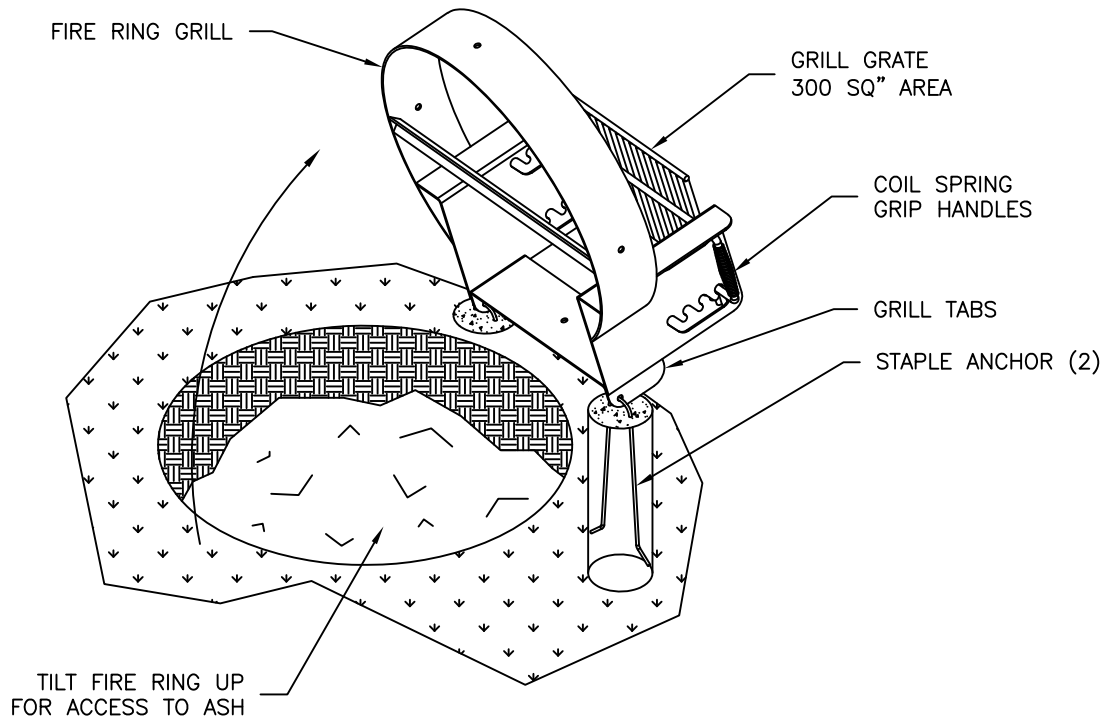

installation: WARNING: The proper installation for these products may depend upon many factors unique to the site, location, or use of a particular product. Consult with your contractor or other professional to determine your specific installation requirements.

product dimensions:

