

*model no:*

SH100D, SH100P

## SHADELAND SERIES

SINGLE POST SHELTER ONLY  
EXPANDED METAL AND PERFORATED PATTERNS

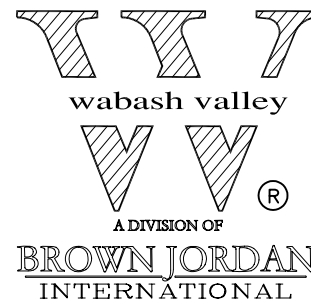

© Wabash Valley Manufacturing, Inc.

### *customer service:*

**ASSEMBLERS:** If you find any parts missing or damaged, or if you're having difficulty assembling your furniture/equipment, call us at:

\* Before calling, have your product model number available.

**1-800-253-8619 (Inside U.S.A.)**

**260-352-2102 (Outside U.S.A.)**

Monday thru Friday,  
8:00 AM - 4:30 PM Eastern Time  
(EXCEPT HOLIDAYS)

Any correspondence concerning our product should be sent directly to our Customer Service Manager at:

Wabash Valley Manufacturing, Inc.  
505 E. Main Street  
P.O.Box 5  
Silver Lake, IN 46982 U.S.A.  
FAX: 260-352-2160

### *maintenance:*

Regular inspection and maintenance of all parts, and fasteners is necessary. Tighten all bolts and nuts. Inspect Tops, Seats, Legs, Braces and Fasteners periodically for wear or vandalism. Replace broken or worn parts immediately or take equipment out of service until repairs are made. Use genuine Wabash Valley replacement parts.

To restore plastisol coating to its luster after prolonged use, wash/rinse/dry and use Armor-All ® or similar quality vinyl protectant.

**KEEP THIS ASSEMBLY/SPECIFICATION SHEET FOR FUTURE REFERENCE.**

### *specifications:*

**NOTE: We reserve the right to change specifications without notice.**

Heat fused poly-vinyl coating, finished on inner-metal structure, to an approximate 3/16" thickness. Framework assemblies are finished with powder coating; electrostatically applied and oven cured according to powder manufacturer's specifications. Fasteners are stainless steel to resist corrosion.

#### FRAME:

The seat assembly main tube consists of 12 gage x 2 7/8" diameter steel tubing with 3/8" thick steel mounting plate. Cross tube is made of 13 gage x 2 3/8" diameter steel tubing. Seat attachment brackets are made of 10 gage sheet steel. The complete seat assembly is zinc plated prior to powder coating.

#### TOP & SEATS:

Top and seats use fabricated 3/4-#9 expanded steel mesh and 12 gage sheet steel for the perforated. Both types of fabricated metals are machine-rolled forming the top and seat's rolled-sides. Top and seat frame mounting brackets are 10 gage sheet steel. The ends of the rolled-sides, of the top and seats, use a 1/2" diameter steel rod, to add support on expanded steel mesh only. The top center ring consists of 6 5/8" OD x 1/4" thick steel tubing.

#### ROOF & SUPPORT:

The roof uses fabricated 3/4-#9 expanded steel mesh and 14 gage sheet steel for the perforated. The edges of the expanded steel mesh are made of 14 gage sheet steel and the ends of the rolled-sides use 5/16" diameter rod to add support. The edge roof strip is made of 14 gage sheet steel. Cross support tubes are made of 10 gage x 1 5/8" diameter steel tubing. The roof support tube pockets consist of #2 or 319 aluminum casting. The support wings are made of 3/8" thick aluminum plate.

#### POST:

The post is made of 5" schedule 40 structural grade aluminum pipe.

#### CAPS & COVERS:

The cap, corner covers and split covers consist of #2 or 319 cast aluminum.

#### GENERAL:

SH100D/SH100P - The ground space requirements are 85 3/8" square, 98 1/2" tall and 84" head clearance.

parts identification:

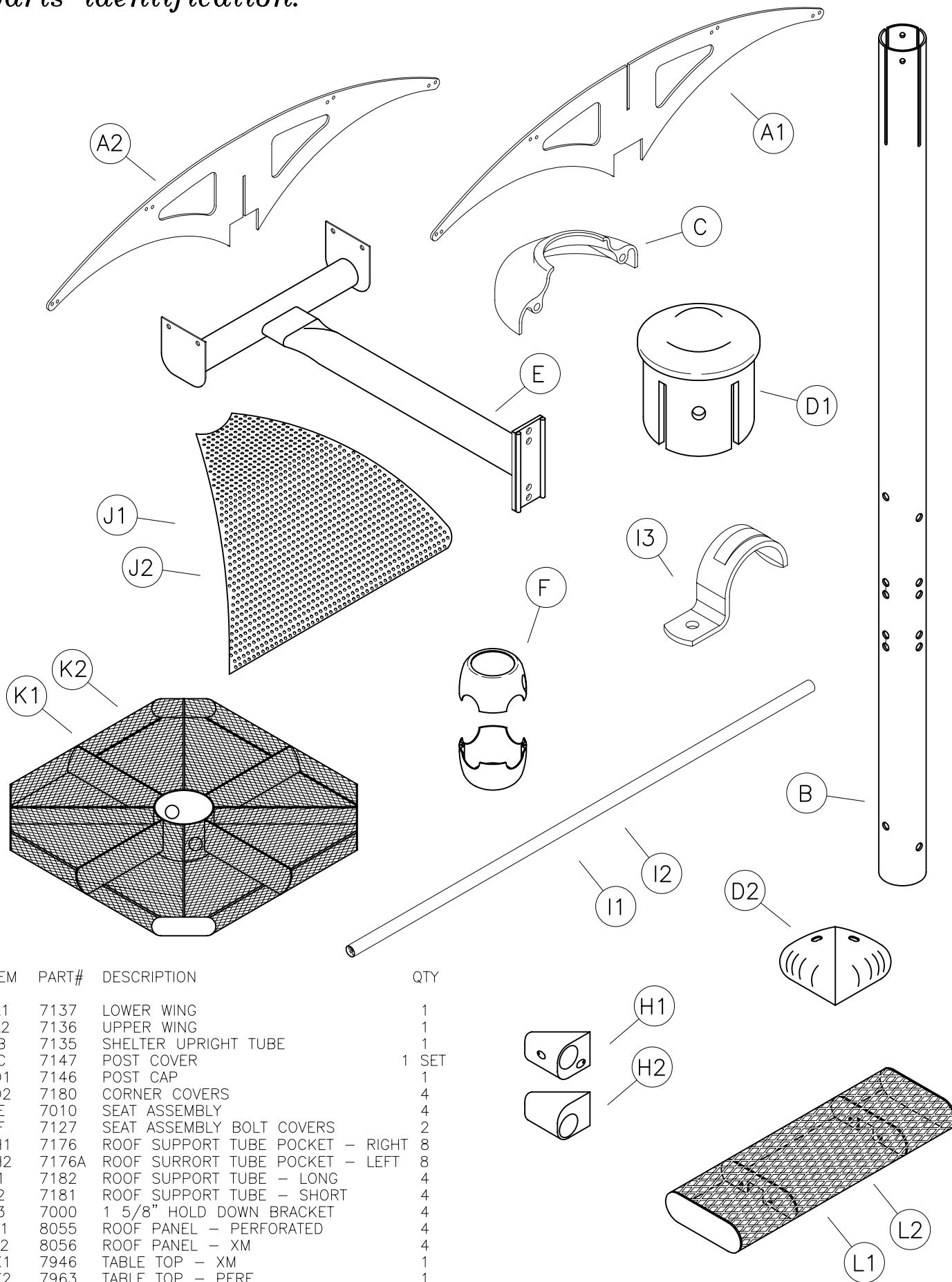

| ITEM | PART# | DESCRIPTION                      | QTY   |
|------|-------|----------------------------------|-------|
| A1   | 7137  | LOWER WING                       | 1     |
| A2   | 7136  | UPPER WING                       | 1     |
| B    | 7135  | SHELTER UPRIGHT TUBE             | 1     |
| C    | 7147  | POST COVER                       | 1 SET |
| D1   | 7146  | POST CAP                         | 1     |
| D2   | 7180  | CORNER COVERS                    | 4     |
| E    | 7010  | SEAT ASSEMBLY                    | 4     |
| F    | 7127  | SEAT ASSEMBLY BOLT COVERS        | 2     |
| H1   | 7176  | ROOF SUPPORT TUBE POCKET - RIGHT | 8     |
| H2   | 7176A | ROOF SURREORT TUBE POCKET - LEFT | 8     |
| I1   | 7182  | ROOF SUPPORT TUBE - LONG         | 4     |
| I2   | 7181  | ROOF SUPPORT TUBE - SHORT        | 4     |
| I3   | 7000  | 1 5/8" HOLD DOWN BRACKET         | 4     |
| J1   | 8055  | ROOF PANEL - PERFORATED          | 4     |
| J2   | 8056  | ROOF PANEL - XM                  | 4     |
| K1   | 7946  | TABLE TOP - XM                   | 1     |
| K2   | 7963  | TABLE TOP - PERF                 | 1     |
| L1   | 7543  | SEAT - XM                        | 4     |
| L2   | 8009  | SEAT - PERF                      | 4     |

**hardware identification:**

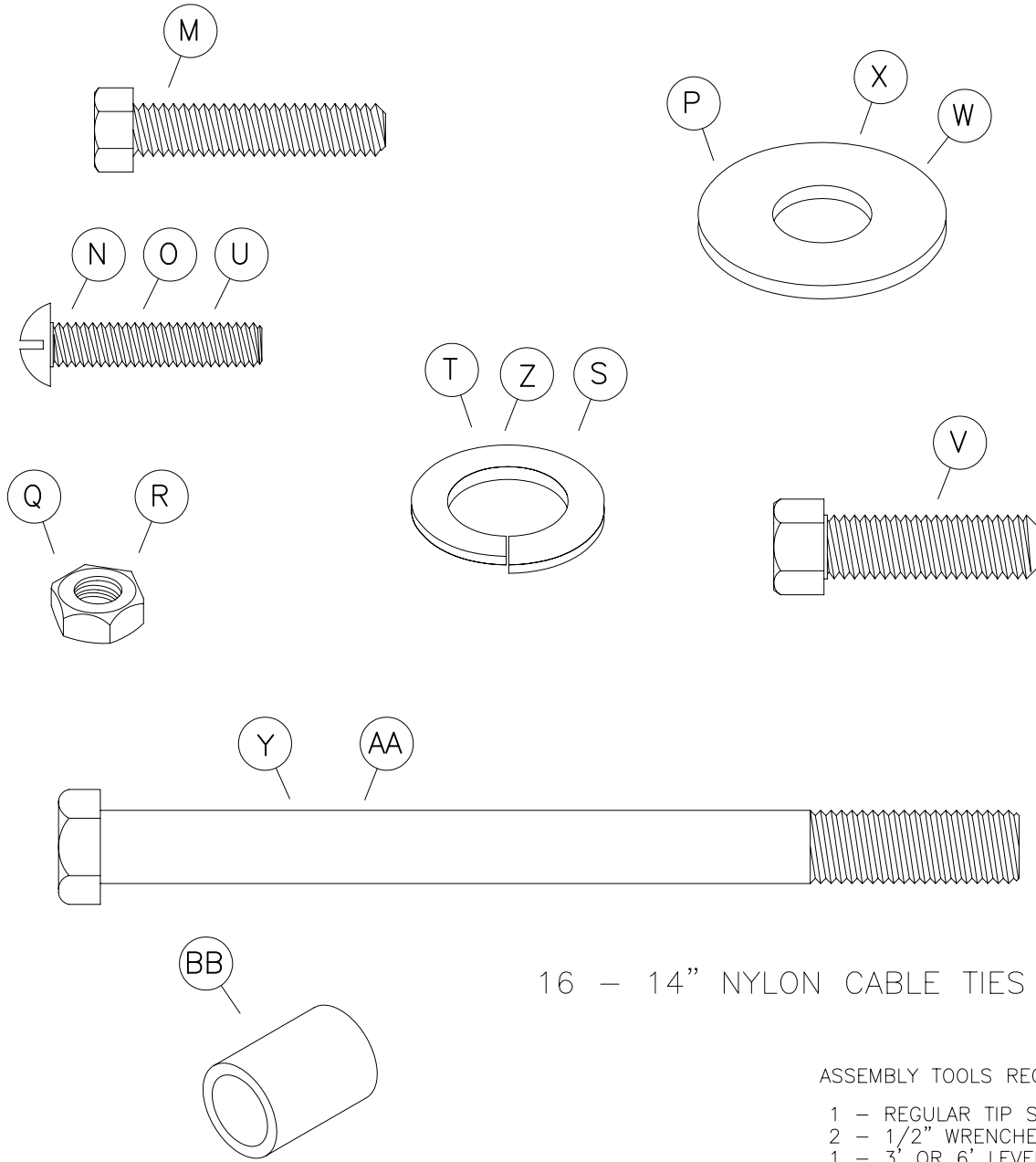

16 - 14" NYLON CABLE TIES

**ASSEMBLY TOOLS REQUIRED**

- 1 - REGULAR TIP SCREWDRIVER
- 2 - 1/2" WRENCHES
- 1 - 3' OR 6' LEVEL
- 1 - 3/4" WRENCH

**ITEMS INCLUDED IN HARDWARE PACKAGE:**

| ITEM | PART# | DESCRIPTION                               | #21138<br>QTY | #21101<br>QTY |
|------|-------|---|---------------|---------------|
| M    | 17011 | 5/16-18 x 1 1/2" HEX BOLT - SS            | 16            | 0             |
| N    | 17052 | 1/4-20 x 1" ROUND HEAD MACHINE SCREW - SS | 16            | 2             |
| O    | 17025 | 5/16-18 x 1 1/2" MACHINE SCREW - SS       | 12            | 0             |
| P    | 17028 | 3/8" FLAT WASHER - SS                     | 56            | 0             |
| Q    | 17032 | 5/16-18 HEX FINISH NUT - SS               | 28            | 0             |
| R    | 17081 | 1/2" HEX FLANGE NUT - SS                  | 6             | 0             |
| S    | 17086 | 1/2" LOCK WASHER - SS                     | 2             | 0             |
| T    | 17050 | 5/16" SPLIT LOCK WASHER - SS              | 28            | 0             |
| U    | 17058 | 5/16-18 x 2" MACHINE SCREW - SS           | 8             | 0             |
| V    | 17102 | 1/2-13 x 1" HEX HEAD BOLT - SS            | 2             | 0             |
| W    | 17103 | 5/16" FLAT WASHER - SS                    | 16            | 0             |
| X    | 17072 | 1/2" FLAT WASHER - SS                     | 8             | 0             |
| Y    | 17107 | 1/2-13 x 7 1/2" HEX HEAD BOLT - SS        | 2             | 0             |
| Z    | 17079 | 1/4" LOCK WASHER - SS                     | 16            | 0             |
| AA   | 17131 | 1/2-13 x 7" HEX HEAD BOLT - SS            | 4             | 0             |
| BB   | 7074  | ø3/4 x 1/2" SLEEVE                        | 4             | 0             |

**assembly procedures:** IMPORTANT: Assemblers should be reasonably skilled in the assembly of commercial grade/heavy duty fabricated steel equipment.

To ensure proper assembly, it is suggested that you take adequate time to locate and identify each part. To prevent scratching of the finished pieces, we recommend this unit to be assembled on a clean, flat, solid, surface with a drop cloth, allowing plenty of working room. Also please read the instructions and study the sketches very carefully. A little extra time spent before assembly will be well worth it in performing a complete, proper assembly. Please note that all parts have been pre-cut and pre-drilled.

During the assembly process leave all bolts and nuts "finger tight", until the entire unit is completely assembled. This allows room for movement to level or adjust all seats, tops, benches, framework and braces if necessary. After final adjustment and leveling, permanently tighten all nuts, bolts and fasteners.

7L

**WARNING: THIS UNIT IS HEAVY AND COMPLEX. DURING INSTALLATION MULTIPLE PERSONNEL AND/OR LIFTING EQUIPMENT NEED TO BE USED TO PREVENT INJURY.**

STEP 1: Locate and prepare the installation site by digging one hole in accordance to your local building codes.

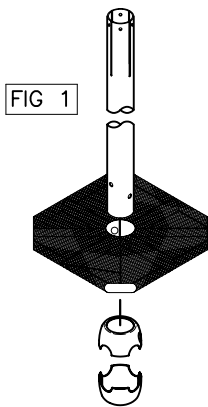

STEP 2: Carefully slide the table top (K-) up the upright tube (B). Also slide the seat assembly bolt covers up under the table top on the upright. A lubricant may be used to prevent scratching of the upright post (See Fig. 1). Align the corners of the table top with the slots for roof. Secure the table assembly to the upright using one hex head bolt (Y), two (W) flat washer, one (S) lock washer, one (R) hex nut and two (BB) sleeves per (Y), per hole. (See Fig. 2) Slide the top bolt cover up and secure to table to keep out of the way of installing the seat arms. Secure opposite seat assembly arms to the upright using two hex head bolts (AA), two flat washers (W), and two hex nuts (R) per assembly pairs, (See Fig 3). Slide bolt covers together and secure with two machine screws (N).

STEP 3: Once Step 2 is completed prepare the installation site in accordance to your local building codes. Place the upright tube into the hole and fill with concrete. Prop the seat assemblies 11 1/4" from the top of the grade by using sturdy objects. When the concrete has fully cured, bolt the seats (L-) to the seat assemblies using one hex head bolt (M), two flat washers (P), one (T) lock washer and one flange nut (Q) per each hole (See Fig 4).

NOTE: Post not shown for clarity.

FIG 2

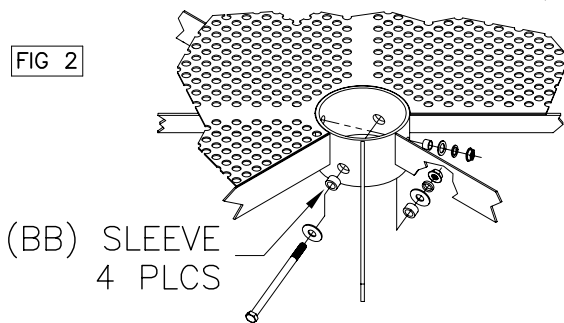

FIG 3

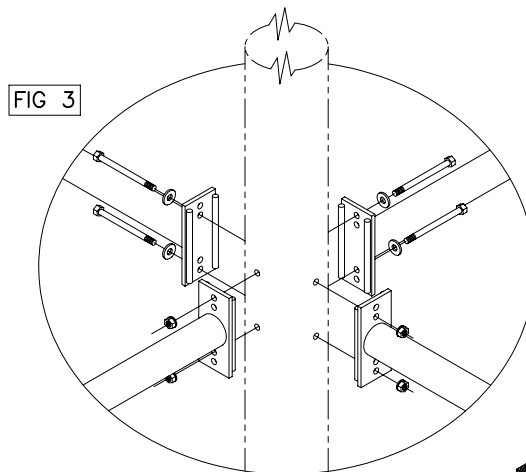
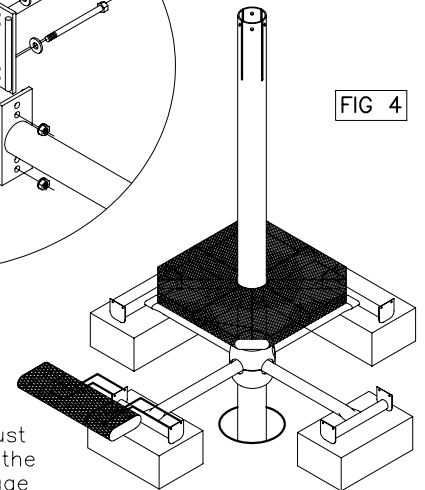

FIG 4



STEP 4: Slide the lower wing (A1) into the grooves in the upright post. Then do the upper wing (A2) interlocking it with the lower wing (See Fig 5).

STEP 5: Bolt the roof support tube pockets (H-) to the wings using two machine screws (N) and two (Z) lock washers per each set of pockets. Tubes must be in pockets simultaneously when bolting tube pockets to wing. To bolt the pockets together pass the bolt through (H1), through the wing, and engage the internal threads of (H2). (See Fig 6).

FIG 5

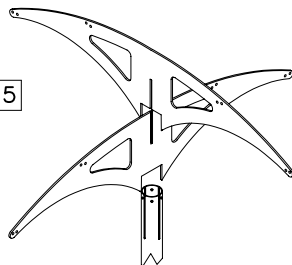
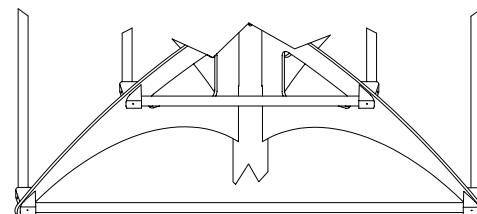

FIG 6



**installation:** WARNING: The proper installation for Wabash Valley products may depend upon many factors unique to the site, location, or use of a particular product. Consult with your contractor or other professional to determine your specific installation requirements.

## product assembly continued:

STEP 7: Carefully lay each roof panel (J-), running clockwise, on the roof support structure. Pull each panel towards the center and ensure all panels are symmetrical and strip on the right side of panel overlaps adjacent panels. Temporarily secure each panel to the support tubes using 14" nylon cable ties, using one per each end. Bolt hold down brackets (I3) to under-side of roof panels, onto support tubes (I2) four places, using one (O), two (P), one (T) and one (Q) per each (O). (SEE FIG 7). Bolt roof corner caps (D2) to the roof panels using one (U), two (P), one (Q) and one (T) per each (U), per each hole. Place the upright tube ensuring to cover the top edge of all the roof panels, and bolt in place using one hex head cap (D1) into the bolt (V) per each hole. (See Fig 8). NOTE: Remove nylon cable ties once panels are secure.

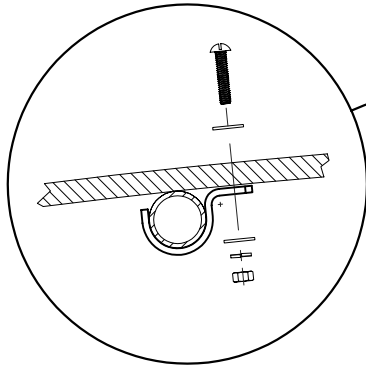

FIG 7

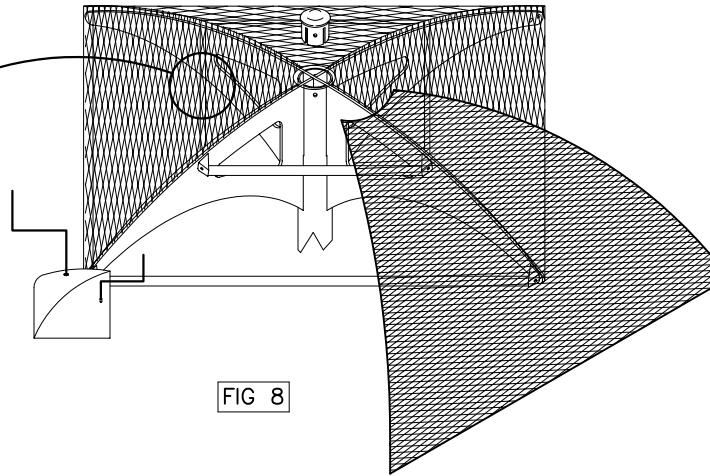

FIG 8

NOTE: This product has been engineered in accordance with the design load provisions of ASCE 7-98 and the design load provisions of the Florida Building Code, 2001, for Miami-Dade County. To support the maximum wind/snow load conditions, the foundations for this product should be engineered on a site specific basis to be able to withstand the ultimate base reactions shown below.

## product dimensions:

