

model no:

SG162D, SG162P,
SG163D, SG163P



WABASH VALLEY

SIGNATURE SERIES

42" ROUND TABLE, 4 & 6 LEG WITH CONCAVE SEATS
EXPANDED METAL & PERFORATED
PORTABLE

© Wabash Valley Manufacturing, Inc.

customer service:

ASSEMBLERS: If you find any parts missing or damaged, or if you're having difficulty assembling your furniture/equipment, call us at:

* Before calling, have your product model number available.

1-800-253-8619 (Inside U.S.A.)
260-352-2102 (Outside U.S.A.)
Monday thru Friday,
8:00 AM - 4:30 PM Eastern Time
(EXCEPT HOLIDAYS)

Any correspondence concerning our product should be sent directly to our Customer Service Manager at:

Wabash Valley Manufacturing, Inc.
505 E. Main Street
P.O.Box 5
Silver Lake, IN 46982 U.S.A.
FAX: 260-352-2160

maintenance:

Regular inspection and maintenance of all parts, and fasteners is necessary. Tighten all bolts and nuts. Inspect Tops, Seats, Legs, Braces and Fasteners periodically for wear or vandalism. Replace broken or worn parts immediately or take equipment out of service until repairs are made. Use genuine Wabash Valley replacement parts.

To restore plastisol coating to its luster after prolonged use, wash/rinse/dry and use Armor-All ® or similar quality vinyl protectant.

KEEP THIS ASSEMBLY/SPECIFICATION SHEET FOR FUTURE REFERENCE.

specifications:

NOTE: We reserve the right to change specifications without notice.

Heat fused poly-vinyl coating, finished on inner-metal structure, to an approximate 3/16" thickness. Framework assemblies are finished with powder coating; electrostatically applied and oven cured according to powder manufacturer's specifications. Fasteners are stainless steel to resist corrosion.

LEG:

Legs are constructed with 2 3/8" od x 12 gage galvanized structural steel tubing. Top and seat mounting brackets are 1/4" plate steel. Center brace is cast aluminum.

TOP AND SEAT:

Tops and seats use fabricated 3/4" x #9 expanded metal and 12 gage sheet metal for the perforated. The top mounting supports are 1/4" x 1 1/2" flat bar. The seat mounting supports are 1/4" plate steel.

GENERAL:

Four leg table ground space requirements are 72 1/2" x 55 3/4". Six leg table ground space requirements are 72 3/4" x 83 9/16". It is 29" to the top of the table and 17" to the top of the seats.

NOTE: When Umbrellas are used on Tables, the Umbrellas must be secured.
Wabash Valley Umbrellas include an Umbrella Collar for securing.

parts identification:

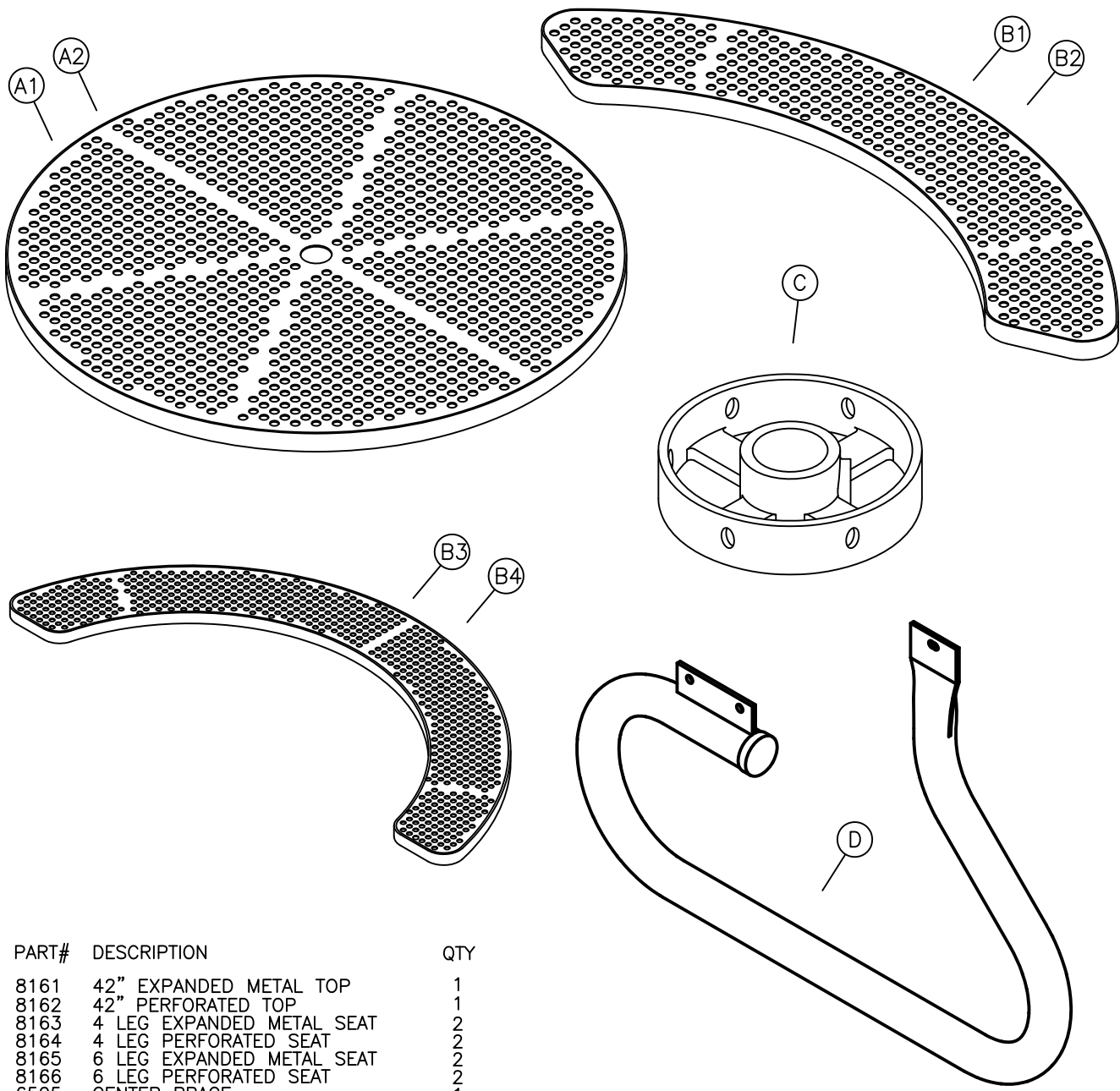

ITEM	PART#	DESCRIPTION	QTY
A1	8161	42" EXPANDED METAL TOP	1
A2	8162	42" PERFORATED TOP	1
B1	8163	4 LEG EXPANDED METAL SEAT	2
B2	8164	4 LEG PERFORATED SEAT	2
B3	8165	6 LEG EXPANDED METAL SEAT	2
B4	8166	6 LEG PERFORATED SEAT	2
C	6505	CENTER BRACE	1
D	6500A	TABLE LEG	4 OR 6

hardware identification:

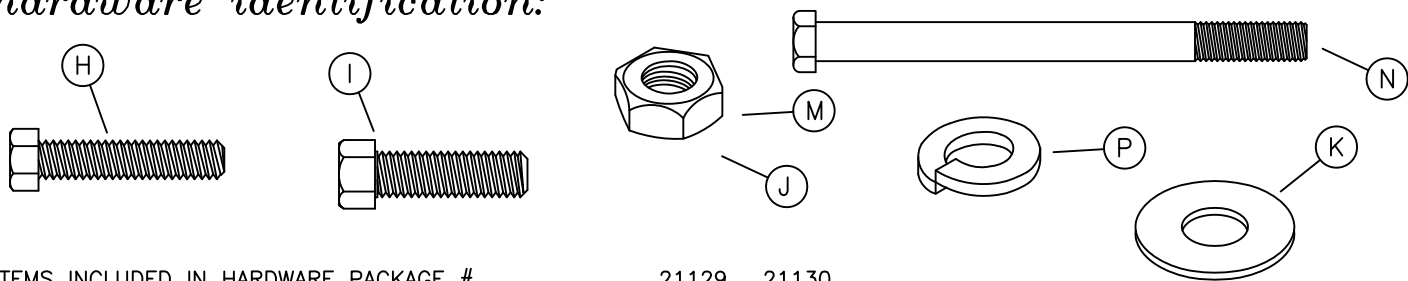

ITEMS INCLUDED IN HARDWARE PACKAGE #			21129	21130
ITEM	PART	DESCRIPTION	QTY	QTY
H	17011	5/16-18 x 1 1/2" HEX HEAD BOLT - SS	18	12
I	17013	3/8-16 x 1 1/4" HEX HEAD BOLT - SS	1	1
J	17019	3/8-16 HEX NUT - SS	6	4
K	17028	3/8" FLAT WASHER - SS	36	24
M	17032	5/16-18 HEX FINISH NUT - SS	18	12
N	17203	3/8-16 X 3" HEX BOLT - SS	6	4
P	17050	5/16" SPLIT LOCK WASHER - SS	18	12

ASSEMBLY TOOLS REQUIRED
 2 - 1/2" WRENCHES
 2 - 9/16" WRENCH
 1 - 3' OR 6' LEVEL

assembly procedures:

IMPORTANT: Assemblers should be reasonably skilled in the assembly of commercial grade/heavy duty fabricated steel equipment.

To ensure proper assembly, it is suggested that you take adequate time to locate and identify each part. To prevent scratching of the finished pieces, we recommend this unit to be assembled on a clean, flat, solid, surface with a drop cloth, allowing plenty of working room. Also please read the instructions and study the sketches very carefully. A little extra time spent before assembly will be well worth it in performing a complete, proper assembly. Please note that all parts have been pre-cut and pre-drilled.

During the assembly process leave all bolts and nuts "finger tight", until the entire unit is completely assembled. This allows room for movement to level or adjust all seats, tops, benches, framework and braces if necessary. After final adjustment and leveling, permanently tighten all nuts, bolts and fasteners.

7L

STEP 1:

Open carton(s) and remove contents. To avoid marring the finish, flatten cardboard carton and proceed to assemble bench on top of the cardboard, on a flat surface.

STEP 2:

Lay top upside down on the cardboard. Assemble legs (4 or 6) to top support brackets using one (H), two (K) and one (M) and one (P) per leg. Loosely attach each leg, in upright position, to the brace using one (N), two (K) and one (J) per leg, inserting bolt first through the leg. Tighten bolts until snug, not tight. Refer to Fig. 1.

Item (I) is used as a set screw to hold umbrella (optional) after inserting through (C).

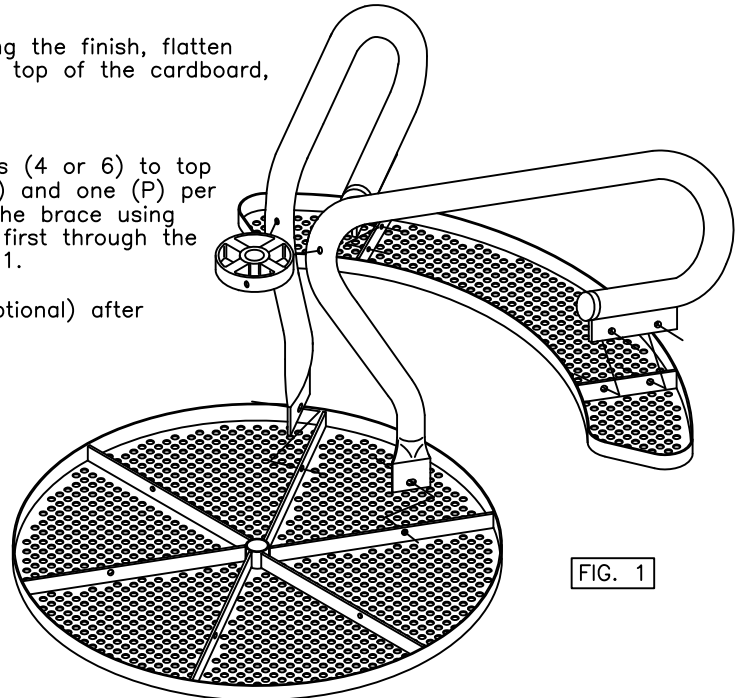

ASSEMBLE CENTER
LEG THIS SIDE

STEP 3:

Re-invert table to right side up position. Place seats on legs with seat mounting brackets on inside of legs. Secure using two (H), one (M) and two (K) and one (P) per (H) per leg.

The middle leg, on the six leg models, is positioned to seat mounting bracket as shown in Fig. 2.

Snug bolts. Level top and seats and tighten bolts with wrenches.

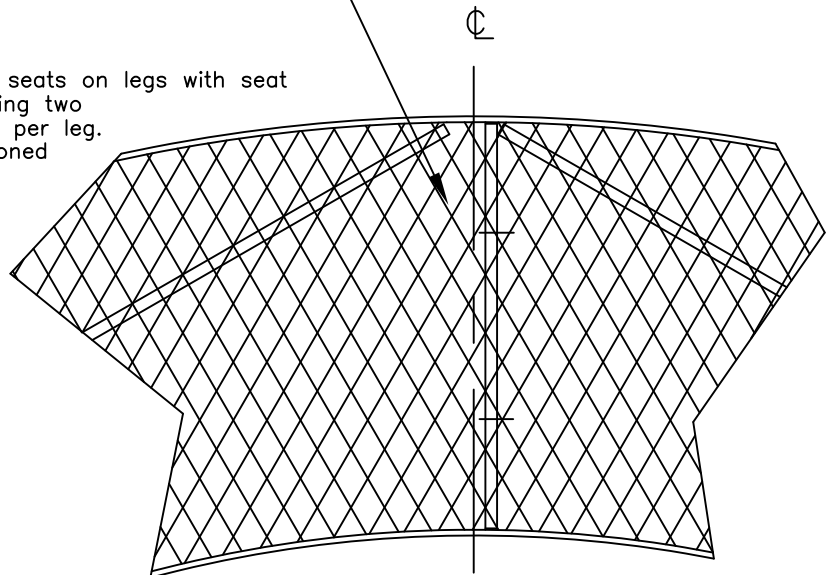

installation:

WARNING: The proper installation for Wabash Valley products may depend upon many factors unique to the site, location, or use of a particular product. Consult with your contractor or other professional to determine your specific installation requirements.

product dimensions:

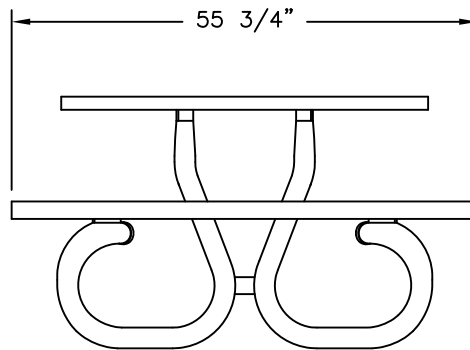
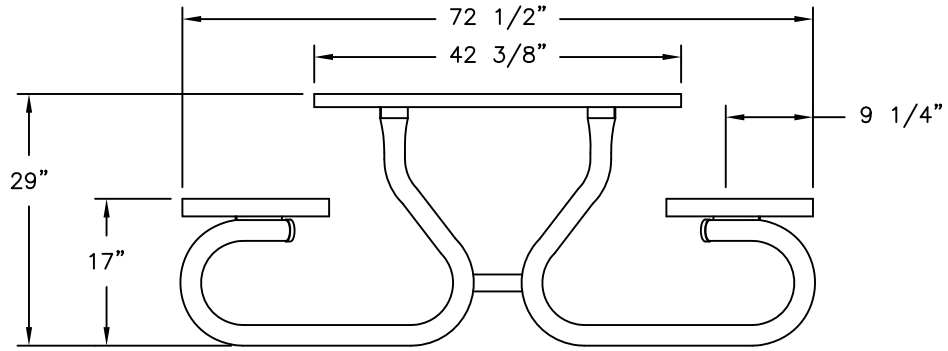

4 LEG ASSEMBLY

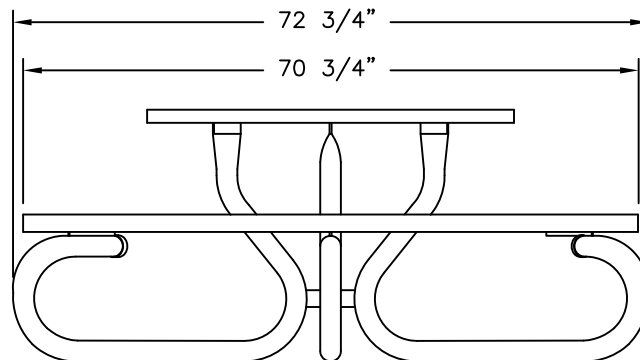
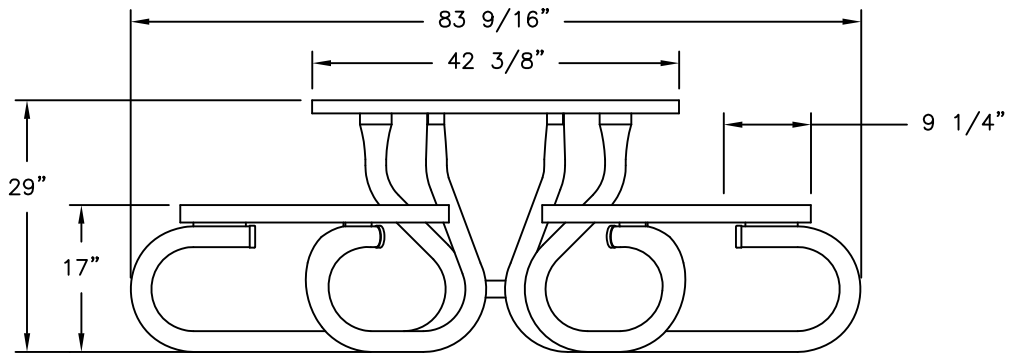

6 LEG ASSEMBLY