

model no:

CA100D, CA100L, CA100P, CA100R, CA101D, CA101L,
CA101P, CA101R, CA102D, CA102L, CA102P, CA102R,
CA103D, CA103L, CA103P, CA103R, CA110D, CA110P,
CA110R, CA111D, CA111P, CA111R, CA300D, CA300P,
CA300R, CA400D, CA400P, CA400R, CA401D, CA401P,
CA401R



WABASH VALLEY

CLASSIC SERIES

CHAIRS, LOVE SEATS, SQUARE & ROUND TABLES
EXPANDED METAL, RIB, PERFORATED & SOLID

© Wabash Valley Manufacturing, Inc.

customer service:

ASSEMBLERS: If you find any parts missing or damaged, or if you're having difficulty assembling your furniture/equipment, call us at:

* Before calling, have your product model number available.

1-800-253-8619 (Inside U.S.A.)
260-352-2102 (Outside U.S.A.)
Monday thru Friday,
8:00 AM - 4:30 PM Eastern Time
(EXCEPT HOLIDAYS)

Any correspondence concerning our product should be sent directly to our Customer Service Manager at:

Wabash Valley Manufacturing, Inc.
505 E. Main Street
P.O.Box 5
Silver Lake, IN 46982 U.S.A.
FAX: 260-352-2160

maintenance:

Regular inspection and maintenance of all parts, and fasteners is necessary. Tighten all bolts and nuts. Inspect Tops, Seats, Legs, Braces and Fasteners periodically for wear or vandalism. Replace broken or worn parts immediately or take equipment out of service until repairs are made. Use genuine Wabash Valley replacement parts.

To restore plastisol coating to its luster after prolonged use, wash/rinse/dry and use Armor-All ® or similar quality vinyl protectant.

KEEP THIS ASSEMBLY/SPECIFICATION SHEET FOR FUTURE REFERENCE.

specifications:

NOTE: We reserve the right to change specifications without notice.

Heat fused poly-vinyl coating, finished on inner-metal structure, to an approximate 3/16" thickness. Framework assemblies are finished with powder coating; electrostatically applied and oven cured according to powder manufacturer's specifications. Fasteners are stainless steel to resist corrosion.

CHAIR, LOVE SEAT, TABLE LEGS, AND CENTER CROSS BRACES:

The chair, love seat, table legs and center cross brace all use #2 cast aluminum.

SEATS, BACKS AND TABLE TOPS:

The table top rib patterns use 10 gage and perforated is 12 gage sheet metal, and the expanded pattern uses 3/4 #9 expanded metal. All mounting brackets are 1/4" flat bar steel. The umbrella collar is 2" od x 14 gage galvanized tube. All edging is done with 1/8" strip steel. The seats and backs are #2 cast aluminum and love seats are constructed of 3/4 #9 expanded metal and 10 gage sheet steel. Solid table tops are aluminum with aluminum mounting brackets. 30" tops do not have an umbrella hole.

GROUND SPACE REQUIREMENTS:

30" pattern and solid table is 30" diameter. 36" pattern table is 36" diameter and 36" solid top is 33 1/2" diameter. 42" pattern and solid table is 42" diameter and 29 7/8" to the top of the table. 48" pattern table is 48" diameter and solid 48" solid top is 45 5/8" diameter. Square tables are 30" x 30" and 36" x 36". All tables are 29 7/8" to the top of the table.

Chairs are 20 7/8" X 24 1/2" and 17 3/8" to the top of the seat.
Love seats are 44 7/8" X 24 1/2" and 17 3/8" to the top of the seat.
For each add-on love seat, add an additional 43 3/4" in length.

NOTE: When Umbrellas are used on Tables, the Umbrellas must be secured.
Wabash Valley Umbrellas include an Umbrella Collar for securing.

parts identification:

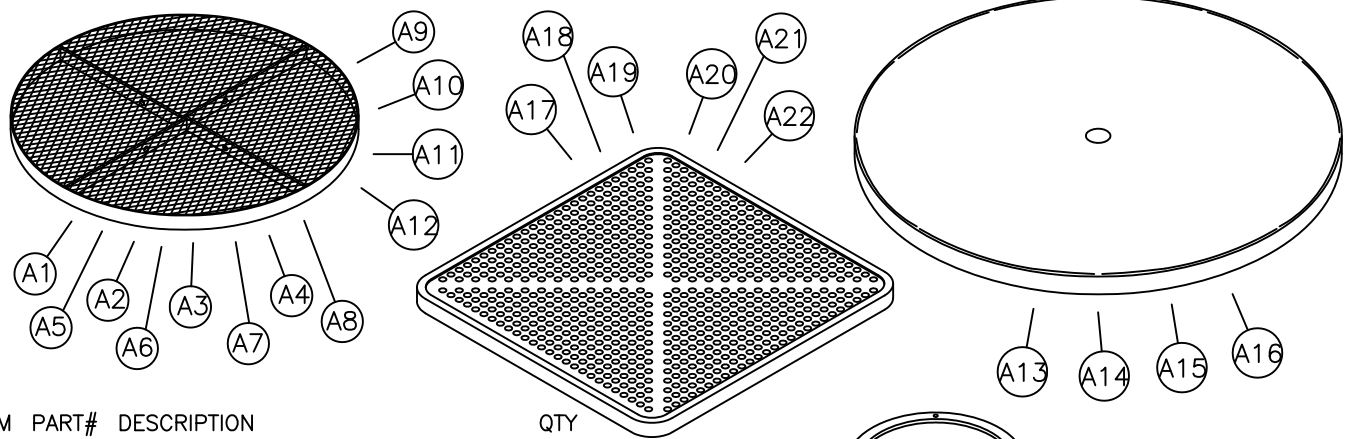

ITEM	PART#	DESCRIPTION	QTY
A1	7524	30" EXPANDED METAL TOP	1
A2	7523	36" EXPANDED METAL TOP	1
A3	7522	42" EXPANDED METAL TOP	1
A4	7521	48" EXPANDED METAL TOP	1
A5	7896	30" RIB TOP	1
A6	7897	36" RIB TOP	1
A7	7898	42" RIB TOP	1
A8	7899	48" RIB TOP	1
A9	7983	30" PERFORATED TOP	1
A10	7982	36" PERFORATED TOP	1
A11	7981	42" PERFORATED TOP	1
A12	7980	48" PERFORATED TOP	1
A13	7039	30" SOLID TOP	1
A14	7040	36" SOLID TOP	1
A15	7041	42" SOLID TOP	1
A16	7042	48" SOLID TOP	1
A17	7647	30" X 30" EXPANDED METAL TOP	1
A18	8167	36" X 36" EXPANDED METAL TOP	1
A19	8168	30" X 30" RIB TOP	1
A20	8169	36" X 36" RIB TOP	1
A21	7986	30" X 30" PERFORATED TOP	1
A22	8170	36" X 36" PERFORATED TOP	1
B1	7220	TABLE LEG	4
B2	7223	CHAIR/LOVE SEAT LEG	2
C1	7202	LARGE TABLE RING	1
C2	7211	SMALL TABLE RING	1
C3	7221	SMALL TABLE CENTER BRACE	1
C4	7222	LARGE TABLE CENTER BRACE	1
D1	7874	EXPANDED METAL CHAIR SEAT	1
D2	7878	RIB CHAIR SEAT	1
D3	7953	PERFORATED CHAIR SEAT	1
D4	7875	EXPANDED METAL CHAIR BACK	1
D5	7879	RIB CHAIR BACK	1
D6	7954	PERFORATED CHAIR BACK	1
D7	7876	EXPANDED METAL LOVE SEAT	1
D8	7880	RIB LOVE SEAT	1
D9	7955	PERFORATED LOVE SEAT	1
D10	7877	EXPANDED METAL LOVE SEAT BACK	1
D11	7881	RIB LOVE SEAT BACK	1
D12	7956	PERFORATED LOVE SEAT BACK	1
E1	7277	SURFACE MOUNT PAD - OPTION	4
E2	17115	ADJUSTABLE GLIDE	4

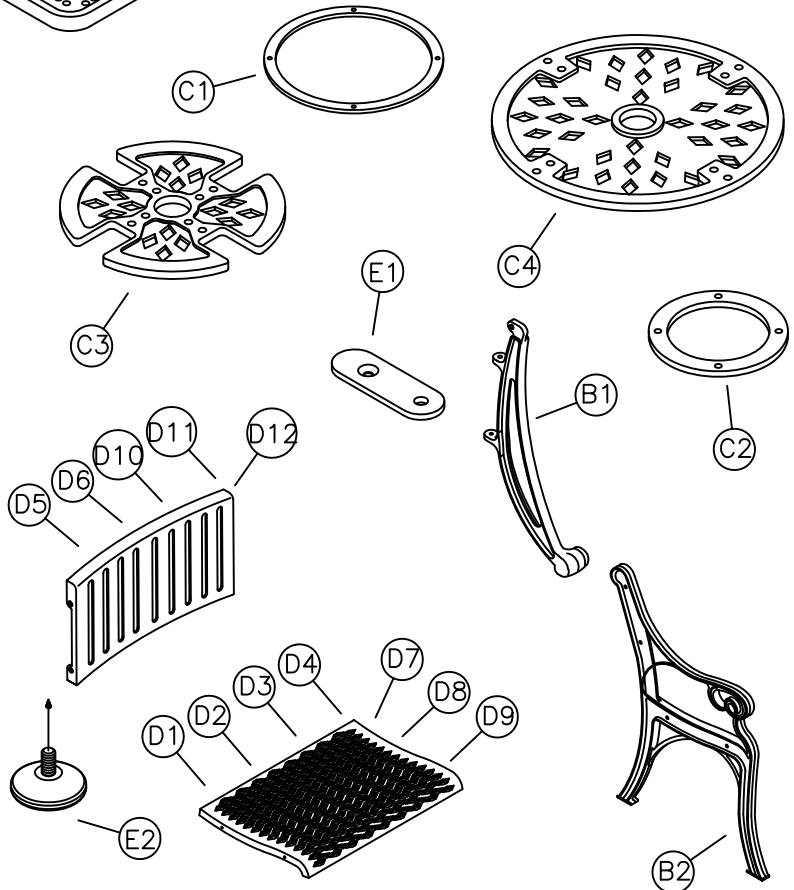

hardware identification:

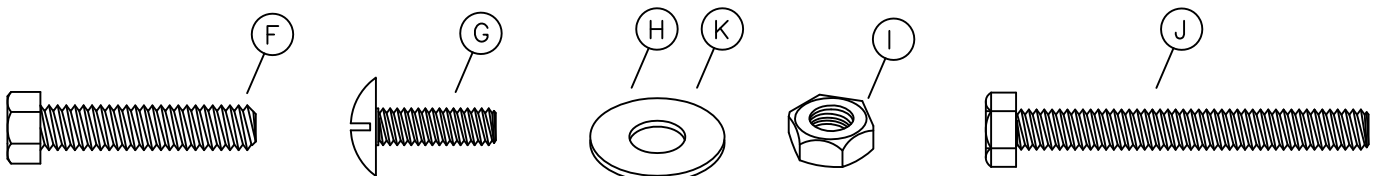

ITEMS INCLUDED IN HARDWARE PACKAGE #

ITEM	PART#	DESCRIPTION	21067 QTY	21068 QTY
F	17011	5/16-18 x 1 1/2" HEX HEAD BOLT - SS	0	4
G	17088	5/16-18 x 1" TRUSS HEAD MACHINE SCREW - SS	8	0
H	17028	3/8" ID x 7/8" OD FLAT WASHER - SS	0	20
I	17032	5/16-18 HEX FINISH NUT - SS	8	16
J	17012	5/16-18 x 2" HEX HEAD BOLT - SS	0	12
K	17103	5/16" FLAT WASHER - SS	8	0
L	17050	5/16" SPLIT LOCK WASHER - SS	8	16

ASSEMBLY TOOLS REQUIRED

- 1 - REGULAR TIP SCREWDRIVER
- 2 - 1/2" WRENCHES
- 1 - 3' OR 6' LEVEL

assembly procedures:

IMPORTANT: Assemblers should be reasonably skilled in the assembly of commercial grade/heavy duty fabricated steel equipment.

To ensure proper assembly, it is suggested that you take adequate time to locate and identify each part. To prevent scratching of the finished pieces, we recommend this unit to be assembled on a clean, flat, solid, surface with a drop cloth, allowing plenty of working room. Also please read the instructions and study the sketches very carefully. A little extra time spent before assembly will be well worth it in performing a complete, proper assembly. Please note that all parts have been pre-cut and pre-drilled.

During the assembly process leave all bolts and nuts "finger tight", until the entire unit is completely assembled. This allows room for movement to level or adjust all seats, tops, benches, framework and braces if necessary. After final adjustment and leveling, permanently tighten all nuts, bolts and fasteners.

7L

STEP 1: Invert top (A-) and attach legs (B1) to opposite side of offset, see FIG. 1, using one (F), two (H) and one (I) and one (L) per (F).

STEP 2: Attach top ring (C1) or (C2) to the top side of the leg upper tabs using one (J), (I), (L) and (H) per (J), per leg, see FIG. 2.

STEP 3: Attach center brace (C3) or (C4) to the top side of the leg's lower mounting tab using two (J), one (I), (L) and one (H) per (J), per leg, FIG. 2. Center brace (C3), shown, has the word **BOTTOM** molded on the bottom of the brace. This must be facing the ground when table is right side up.

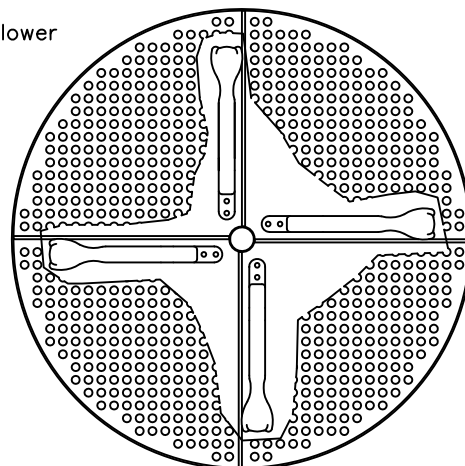
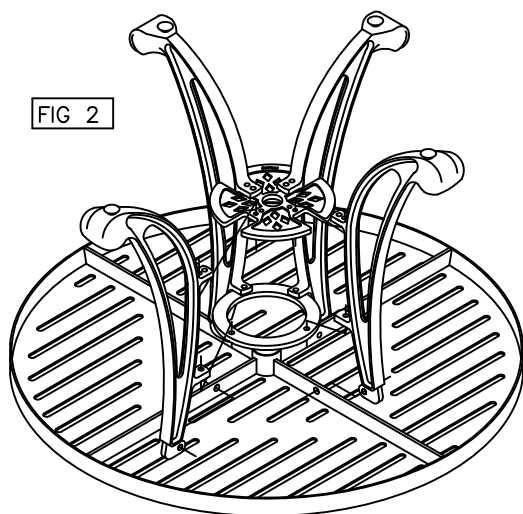

STEP 4: Re-invert table to its topside position. Level the table and tighten all hardware with proper tools.

Assembly of small brace (C3) and small ring (C1) shown.

STEP 1: Attach back (D-) to leg (B2) using two (G), (I) and one (L).

STEP 2: Attach seat (D-) to leg (B2) in the same manner as the seat was attached.

STEP 3: Repeat STEPS 1 and 2 to complete installation for opposite side. See FIG. 3.

STEP 4: Level the seat and back and tighten with proper tools.

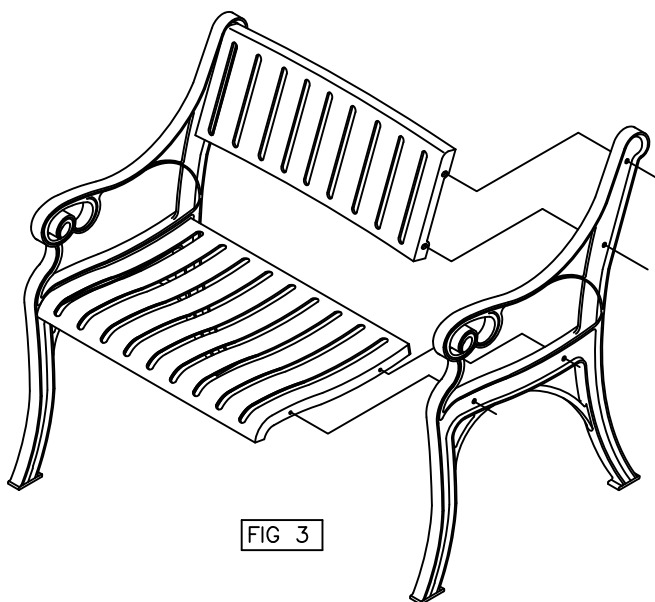

installation:

WARNING: The proper installation for Wabash Valley products may depend upon many factors unique to the site, location, or use of a particular product. Consult with your contractor or other professional to determine your specific installation requirements.

product dimensions:

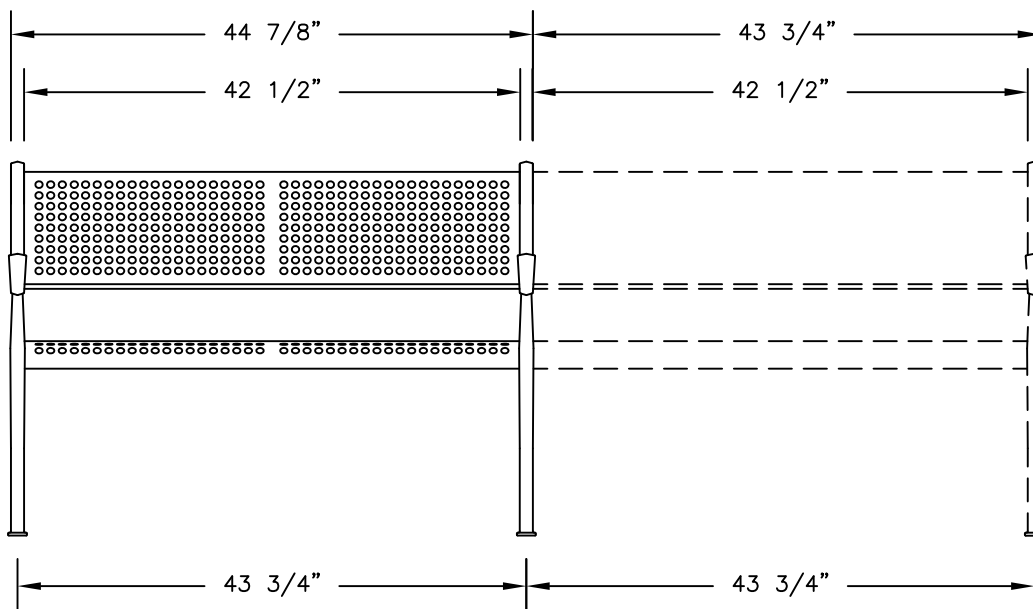
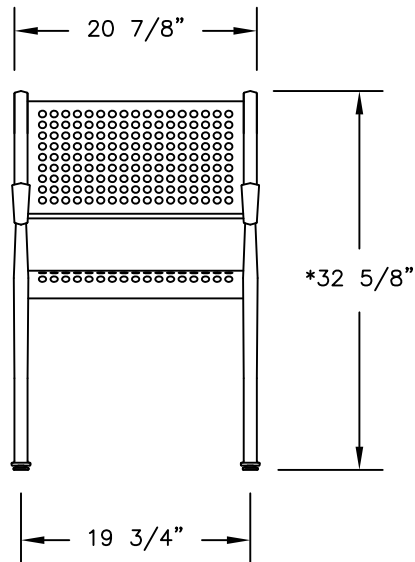
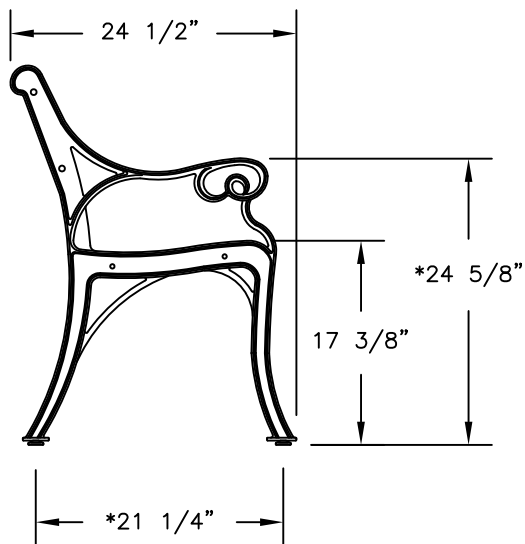

- 30" RND/SQ/SOLID = 30"
- 36" RND/SQ = 36"
- 36" SOLID = 33 1/2"
- 42" RDN/SOLID = 42"
- 48" RND = 48"
- 48" SOLID = 45 5/8"

ALL TABLES
ARE 29 7/8"

* = WITH GLIDES

