

*model no:*

SG205D, SG205P, SG206D,  
SG206P, SG207D, SG207P



## SIGNATURE SERIES

6', 8' & 8' HANDICAP PICNIC TABLES – EXPANDED METAL  
& PERFORATED – MULTI-PEDESTAL INGROUND

© Wabash Valley Manufacturing, Inc.

## *customer service:*

**ASSEMBLERS:** If you find any parts missing or damaged, or if you're having difficulty assembling your furniture/equipment, call us at:

\* Before calling, have your product model number available.

**1-800-253-8619 (Inside U.S.A.)**

**260-352-2102 (Outside U.S.A.)**

Monday thru Friday,  
8:00 AM – 4:30 PM Eastern Time  
(EXCEPT HOLIDAYS)

Any correspondence concerning our product should be sent directly to our Customer Service Manager at:

Wabash Valley Manufacturing, Inc.  
505 E. Main Street  
P.O.Box 5  
Silver Lake, IN 46982 U.S.A.  
FAX: 260-352-2160

## *maintenance:*

Regular inspection and maintenance of all parts, and fasteners is necessary. Tighten all bolts and nuts. Inspect Tops, Seats, Legs, Braces and Fasteners periodically for wear or vandalism. Replace broken or worn parts immediately or take equipment out of service until repairs are made. Use genuine Wabash Valley replacement parts.

To restore plastisol coating to its luster after prolonged use, wash/rinse/dry and use Armor-All ® or similar quality vinyl protectant.

**KEEP THIS ASSEMBLY/SPECIFICATION SHEET FOR FUTURE REFERENCE.**

## *specifications:*

**NOTE: We reserve the right to change specifications without notice.**

Heat fused poly-vinyl coating, finished on inner-metal structure, to an approximate 3/16" thickness. Framework assemblies are finished with powder coating; electrostatically applied and oven cured according to powder manufacturer's specifications. Fasteners are stainless steel to resist corrosion.

### TABLE FRAME:

Main support is constructed from a 4" x 4" x 11 gage galvanized structural steel square tubing. Seats inground post mounting brackets are 1/4" x 1 1/2" steel flat bar, the top plate is made of 10 gage sheet steel. Top's inground post mounting bracket is 7 gage sheet steel, the top plate is 14 gage sheet steel and the gusset is made of 1/8" x 1" strip steel.

### TOP & SEAT:

Top and seat use fabricated 3/4" #9 expanded steel mesh and perforated uses 12 gage sheet metal. Framing consists of 10 gage mitered angles 3/4" x 1 3/4". Top and seat center brace and mounting brackets are 1/4" x 1 1/2" steel flat bar.

### GENERAL:

SG205P and SG205D ground space requirements are 63 3/8" x 72 3/8". Table top is 30 3/8" wide and 30" to the top of the table. Seats are 10 3/8" wide and 19" to the top of seat. Corner radius is 3" to the outside.

SG206P and SG206D ground space requirements are 63 3/8" x 96 3/8". Table top is 30 3/8" wide and 30" to the top of the table. Seats are 10 3/8" wide and 19" to the top of seat. Corner radius is 3" to the outside.

SG207P and SG207D ground space requirements are 63 3/8" x 96 3/8". Table top is 30 3/8" wide and 31 1/2" to the top of the table. Seats are 10 3/8" wide and 19" to the top of seat. Corner radius is 3" to the outside.

*parts identification:*

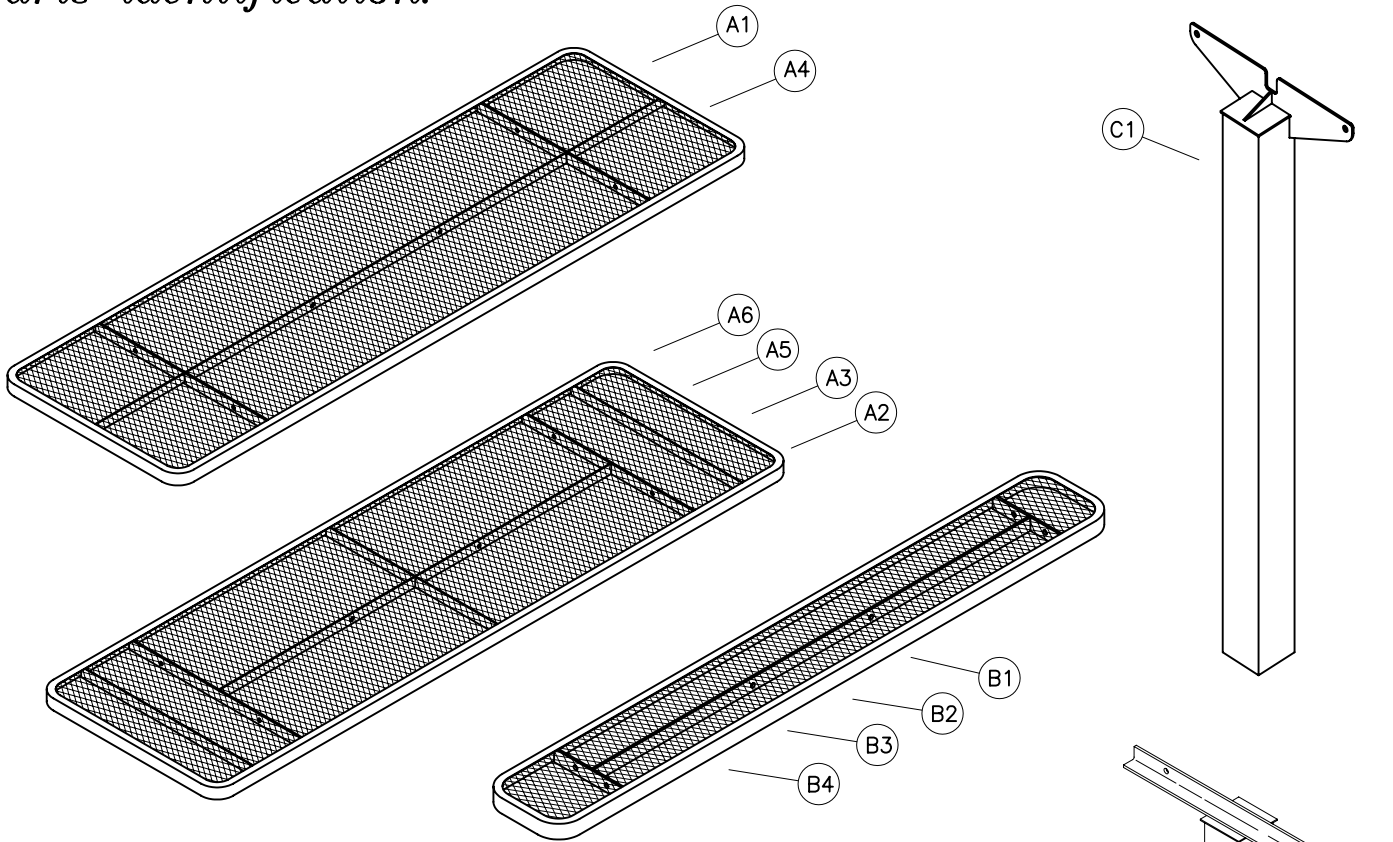

ITEM	PART#	DESCRIPTION	QTY
A1	7520R	8' EXPANDED METAL HANDICAP TOP	1
A2	7502R	6' EXPANDED METAL TOP	1
A3	7501R	8' EXPANDED METAL TOP	1
A4	7961	8' PERFORATED HANDICAP TOP	1
A5	7964	6' PERFORATED TOP	1
A6	7960	8' PERFORATED TOP	1
B1	7529R	6' EXPANDED METAL SEAT	2
B2	7527R	8' EXPANDED METAL SEAT	2
B3	7994	6' PERFORATED SEAT	2
B4	7992	8' PERFORATED SEAT	2
C1	7474	8' HANDICAP INGROUND POST	2
C2	7305	INGROUND TABLE POST	2
D1	7322	INGROUND SEAT POST	4
D2	7151	MOUNTING PLATE COVER (OPTIONAL)	6 SETS

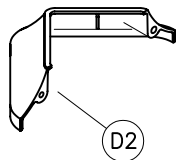

*hardware identification:*

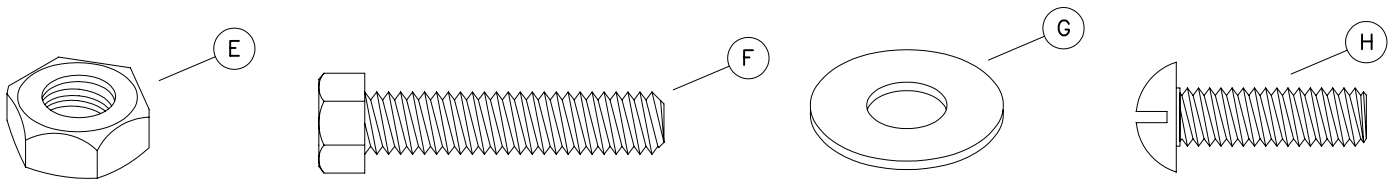

ITEMS INCLUDED WITH HARDWARE PACKAGE:			#21014	#21101
ITEM	PART#	DESCRIPTION	QTY	QTY
E	17032	5/16-18 HEX FINISH NUTS - SS	4	0
F	17011	5/16-18 x 1 1/2" HEX HEAD BOLT - SS	4	0
G	17028	3/8" FLAT WASHER - SS	8	0
H	17052	1/4-20 x 1" MACHINE SCREW - SS	0	2
J	17050	5/16" SPLIT LOCK WASHER - SS	4	0

ASSEMBLY TOOLS REQUIRED

- 2 - 1/2" WRENCHES
- 1 - TAPE MEASURE
- 1 - 3' OR 6' LEVEL
- 1 - FLAT SCREW DRIVER

**assembly procedures:** IMPORTANT: Assemblers should be reasonably skilled in the assembly of commercial grade/heavy duty fabricated steel equipment.

To ensure proper assembly, it is suggested that you take adequate time to locate and identify each part. To prevent scratching of the finished pieces, we recommend this unit to be assembled on a clean, flat, solid, surface with a drop cloth, allowing plenty of working room. Also please read the instructions and study the sketches very carefully. A little extra time spent before assembly will be well worth it in performing a complete, proper assembly. Please note that all parts have been pre-cut and pre-drilled.

During the assembly process leave all bolts and nuts "finger tight", until the entire unit is completely assembled. This allows room for movement to level or adjust all seats, tops, benches, framework and braces if necessary. After final adjustment and leveling, permanently tighten all nuts, bolts and fasteners.

76

**STEP 1**

Invert the (A-) top so it's upside down on a flat surface. Attach each (C-) top's inground post to the outside of the top's mounting brackets, see FIG. 1. Use two, per each bracket, (F) and (E) using two (G) and one (J) per (F). Draw the fasteners to a snug fit with wrenches.

**STEP 2**

Invert both (B-) seats so they're upside down on a flat surface. Attach the four (D) seat's inground post to the outside of each seat's mounting brackets, see FIG. 2. Use two, per each bracket, (F) and (E) using two (G) and one (J) per (F). Draw the fasteners to a snug fit with wrenches.

FIG. 1

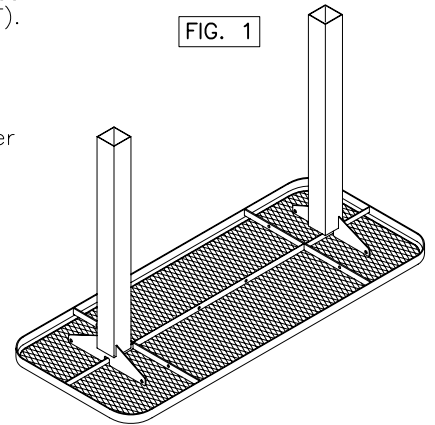

**STEP 3**

Prepare six foundation holes as shown on page four. The distance of holes, center to center, are shown in a diagram on the backside of this assembly instruction sheet.

**STEP 4**

Re-invert the table and seats to their topside up position and place them in the footing holes. Block the table and seats as shown in FIG. 3.

Before pouring concrete, make sure the table and seats are level horizontally as well as vertically and holds 29", for standard, or 31 1/2", for handicap, to the top of the table, and 19" to the top of the seats.

Pour concrete to form the footings and let cure for 48 hours.

**STEP 5**

Tighten all fasteners with wrenches.

If mounting plate covers (D2) are used, place halves around legs and secure with 2 (H) screws, see FIG. 4. Draw to a snug fit being careful not to over tighten.

FIG. 2

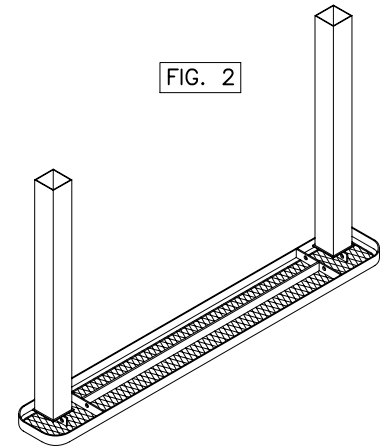

FIG. 3

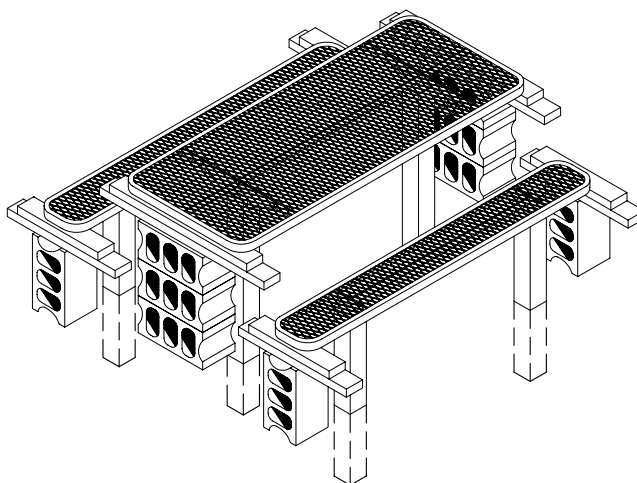
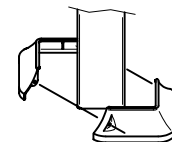

FIG. 4



**installation:** WARNING: The proper installation for Wabash Valley products may depend upon many factors unique to the site, location, or use of a particular product. Consult with your contractor or other professional to determine your specific installation requirements.

*assembly procedures, cont'd:*

*product dimensions:*

